

MV-CS050-10GM/GC-PRO

5 MP 2/3" CMOS GigE Area Scan Camera



GEN*i*CAM

GigE
VISION

Introduction

With GigE interface, MV-CS050-10GM/GC-PRO camera adopts Sony® IMX264 sensor to provide high-quality image and transmit images in real time. Its max. frame rate can reach 24.2 fps in full resolution, and reach 35.6 fps when the image compression mode is enabled.

Key Feature

- Adopts brand new design to reduce power consumption.
- Supports image compression mode and noise reduction function.
- Compact design with mounting holes on panels for flexible mounting from 4 sides.
- Adopts GigE interface and max. transmission distance of 100 meters without relay.
- Compatible with GigE Vision V2.0 Protocol, GenICam Standard, and third-party software based on the protocol and standard.

Dimension

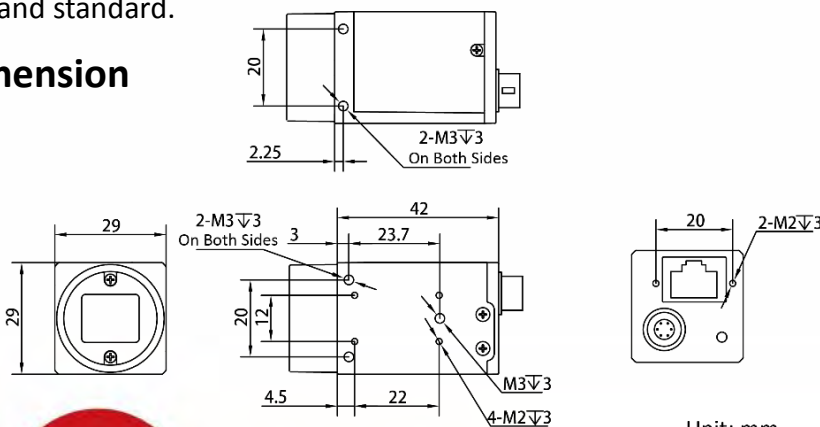

Unit: mm

Available Model

- Mono camera: MV-CS050-10GM-PRO
- Color camera: MV-CS050-10GC-PRO

Applicable Industry

SMT/ PCB AOI, consumer electronics, electrical semiconductor, etc.

Sensor Quantum Efficiency

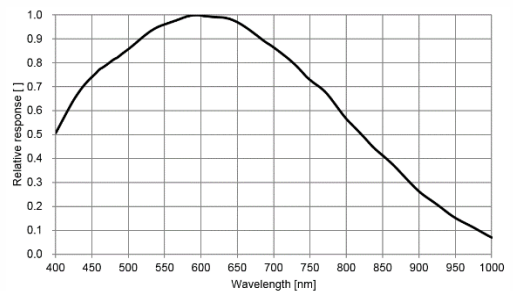

MV-CS050-10GM-PRO

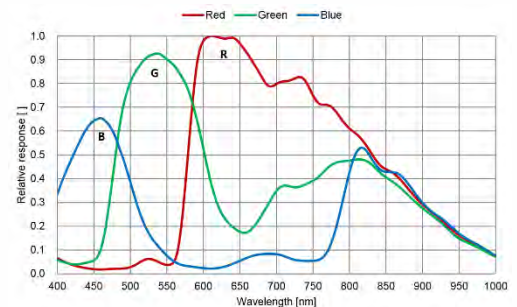

MV-CS050-10GC-PRO



Specification

Model	MV-CS050-10GM-PRO	MV-CS050-10GC-PRO
Camera		
Sensor type	CMOS, global shutter	
Sensor model	Sony® IMX264	
Pixel size	3.45 μm × 3.45 μm	
Sensor size	2/3"	
Resolution	2448 × 2048	
Max. frame rate	24.2 fps @2448 × 2048	
	35.6 fps @2448 × 2048 (image compression mode enabled)	
Dynamic range	72 dB	
SNR	40 dB	
Gain	0 dB to 24 dB	
Exposure time	UltraShort exposure mode: 1 μs to 14 μs	
	Standard exposure mode: 15 μs to 10 sec	
Exposure mode	Off/Once/Continuous exposure mode	
Mono/color	Mono	Color
Pixel format	Mono 8/10/10p/12/12p	Mono 8/10/12, Bayer RG 8/10/10p/12/12p, YUV422Packed, YUV422_YUYV_Packed, RGB 8, BGR 8
Binning	Supports 1 × 1, 1 × 2, 1 × 4, 2 × 1, 2 × 2, 2 × 4, 4 × 1, 4 × 2, 4 × 4	
Decimation	Supports 1 × 1, 2 × 2	
Reverse image	Supports horizontal and vertical reverse image output	
Electrical features		
Data interface	Gigabit Ethernet, compatible with Fast Ethernet	
Digital I/O	6-pin Hirose connector provides power and I/O, including opto-isolated input × 1 (Line 0), opto-isolated output × 1 (Line 1), bi-directional non-isolated I/O × 1 (Line 2).	
Power supply	9 VDC to 24 VDC, supports PoE	
Power consumption	Typ. 2.6 W@12 VDC	Typ. 2.9 W@12 VDC
Mechanical		
Lens mount	C-Mount	
Dimension	29 mm × 29 mm × 42 mm (1.1" × 1.1" × 1.2")	
Weight	Approx. 100 g (0.22 lb.)	
Ingress protection	IP40 (under proper lens installation and wiring)	
Temperature	Working temperature: -30 °C to 60 °C (-22 °F to 140 °F)	
	Storage temperature: -30 °C to 70 °C (-22 °F to 158 °F)	
Humidity	20% to 95% RH, non-condensing	
General		
Client software	MVS or third-party software meeting with GigE Vision Protocol	
Operating system	32/64-bit Windows XP/7/10, 32/64-bit Linux and 64-bit MacOS	
Compatibility	GigE Vision V2.0, GenICam	
Certification	CE, FCC, RoHS, KC	

HIKROBOT

Hangzhou Hikrobot Technology Co., Ltd.
No.399 Danfeng Road, Binjiang District, Hangzhou 310051, China.
en.hikrobotics.com

MaxxVision®

Sigmaringer Str. 121
70567 Stuttgart
Tel.: 0711 997 996 3

www.maxxvision.com

Copyright Hikrobot

Hangzhou Hikrobot Technology Co., Ltd. All Rights Reserved. Hangzhou Hikrobot Technology does not tolerate any infringement. / content. The data herein is based on Hikrobot's internal evaluation. Actual data may vary depending on specific configuration of the content has been checked conscientiously. Nevertheless, Hikrobot shall not be liable to damages resulting from errors, INCONSISTENCIES or OMISSIONS.