

MV-CH050-90XM

5 MP 1/2" CMOS CoaXPress Area Scan Camera



GEN<i>i>CAM

Introduction

MV-CH050-90XM camera adopts Gpixel GMAX2505 sensor to provide high quality image. It uses CXP-6 interface to transmit non-compressed images in real time, and its max. frame rate can reach 213 fps in full resolution.

Key Feature

- Resolution of 2592 × 2160, pixel size of 2.5 μm × 2.5 μm.
- Adopts global shutter CMOS sensor to provide high dynamic range, SNR, and high-quality image.
- Adopts CXP-6 interface to transmit data.
- Supports Off, Once, and Continuous exposure modes.
- Compatible with CoaXPress Protocol, GenICam Standard, and third-party software based on the protocol and standard.

Available Model

MV-CH050-90XM-C-NN

Applicable Industry

Electron semiconductor, PCB AOI, 3D application, motion capture, etc.

Sensor Quantum Efficiency

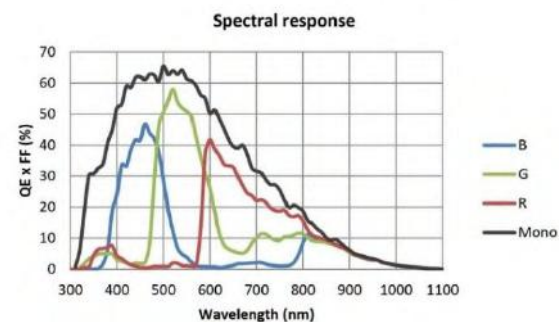

Dimension

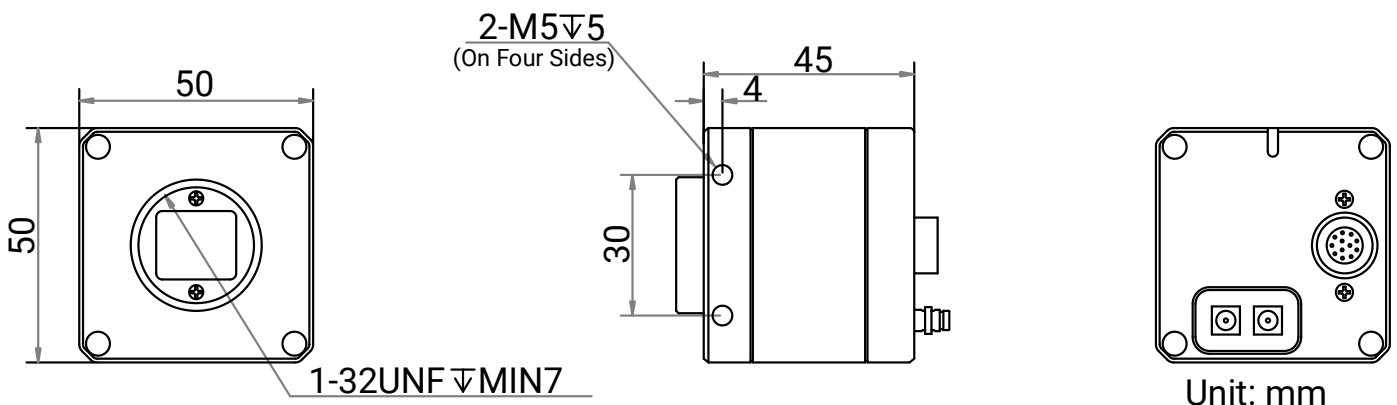

Specification

Model	MV-CH050-90XM
Performance	
Sensor type	CMOS, global shutter
Sensor model	Gpixel GMAX2505
Pixel size	2.5 μm \times 2.5 μm
Sensor size	1/2"
Resolution	2592 \times 2160
Max. frame rate	213 fps @2592 \times 2160 Mono 8
Dynamic range	63.8 dB
SNR	37 dB
Gain	1.0 \times , 1.25 \times , 1.5 \times , 1.75 \times , 2.0 \times
Exposure time	5 μs to 10 sec
Exposure mode	Off/Once/Continuous exposure mode
Mono/color	Mono
Pixel format	Mono 8/12
Binning	Supports 1 \times 1, 1 \times 2, 1 \times 4, 2 \times 1, 2 \times 2, 2 \times 4, 4 \times 1, 4 \times 2, 4 \times 4
Decimation	Supports 1 \times 1, 1 \times 2, 1 \times 4, 2 \times 1, 2 \times 2, 2 \times 4, 4 \times 1, 4 \times 2, 4 \times 4
Reverse image	Supports horizontal and vertical reverse image output
Electrical features	
Data interface	CoaXPress with DIN interface
Digital I/O	12-pin P10 connector provides power and I/O, including opto-isolated input \times 1 (Line 0), opto-isolated output \times 1 (Line 1), bi-directional non-isolated I/O \times 1 (Line 2), and RS-232 \times 1.
Power supply	9 VDC to 24 VDC, CXP-1 supports PoCXP
Power consumption	Typ. 5.3 W@12 VDC
Mechanical	
Lens mount	C-mount, flange focal length 17.52 mm (0.7")
Dimension	50 mm \times 50 mm \times 45 mm (2.0" \times 2.0" \times 1.8")
Weight	Approx. 220 g (0.5 lb.)
Ingress protection	IP40 (under proper lens installation and wiring)
Temperature	Working temperature: 0 $^{\circ}\text{C}$ to 50 $^{\circ}\text{C}$ (32 $^{\circ}\text{F}$ to 122 $^{\circ}\text{F}$) Storage temperature: -30 $^{\circ}\text{C}$ to 70 $^{\circ}\text{C}$ (-22 $^{\circ}\text{F}$ to 158 $^{\circ}\text{F}$)
Humidity	20% to 95% RH, non-condensing
General	
Client software	MVS or third-party software meeting with CoaXPress Protocol
Operating system	32/64-bit Windows 7/10, 64-bit Windows 11, 32/64-bit Linux
Compatibility	CoaXPress, GenICam
Certifications	CE, RoHS, KC