

MV-CH310-10GM-F-NF

31 MP CMOS Area Scan Camera

Introduction

MV-CH310-10GM-F-NF is a high-end area scan camera of the CH series. It adopts Sony IMX 342 CMOS sensor and provides high quality image with high resolution and low noise. The Gigabit Ethernet interface provides high speed real-time transmission of uncompressed data.



GIGAVISION GEN<i>i</i>CAM

Key Feature

- Supports auto and manual adjustment for gain, exposure control, white balance, LUT, Gamma correction, and etc.
- Supports hardware triggering, software triggering and free run mode
- Customized ROI allows to increase the frame rate via resolution reduction
- Supports horizontal and vertical reverse image output

Applicable Industry

PCB AOI, FPD, railway, aerial photograph, document scanning and etc.

Available Model

Mono camera: MV-CH310-10GM-F-NF

Sensor Quantum Efficiency

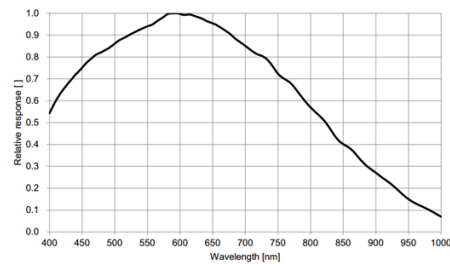

Dimension

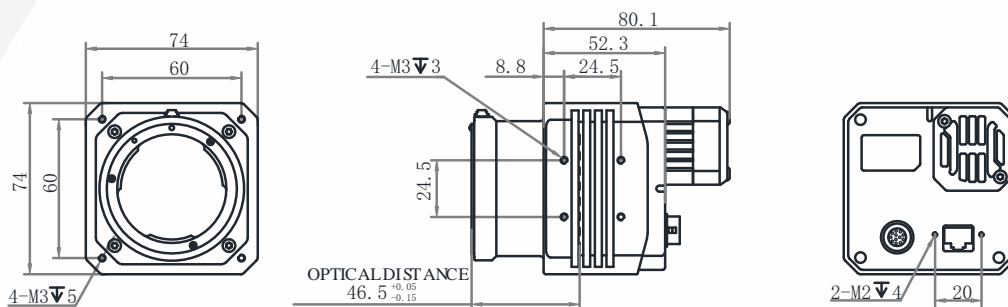

Unit: mm



Specification

| | |
|----------------------------|---|
| Model | MV-CH310-10GM-F-NF |
| Parameters | 31 MP CMOS Area Scan Camera |
| Camera | |
| Sensor type | CMOS, global shutter |
| Sensor model | IMX 342 |
| Pixel size | 3.45 μm \times 3.45 μm |
| Sensor size | 24.9 mm(H) \times 16.6 mm(V) |
| Resolution | 6464 \times 4852 |
| Maximum Frame rate | Mono8 3.9fps |
| Dynamic range | 73 dB |
| SNR | 40 dB |
| Gain | 0 dB to 24 dB |
| Exposure time | Minimum exposure: 3 μs to 33 μs ; normal exposure: 36 μs to 2 s |
| Shutter mode | Off/ Once /Continuous exposure mode |
| Pixel format | Mono 8/10/10p/12/12p |
| Acquisition mode | Continuous mode, single frame mode |
| Binning | 2 \times 2 |
| Decimation | 2 \times 2 |
| Reverse image | Supports horizontal and vertical reverse image output |
| Image buffer | 256 MB |
| Electrical features | |
| Data interface | Gigabit Ethernet |
| Digital I/O | 12-pin Hirose connector provides power supply and I/O, including opto-isolated Input x 1 (Line 0), opto-isolated output x 1 (Line 1), bi-directional non-isolated I/O x 1 (Line 2), RS232 x 1, and RS485 x 1 |
| Power supply | 9 VDC to 26 VDC |
| Power consumption | 9 W@12 VDC |
| Structure | |
| Lens mount | F-Mount, back optical focal length: 46.5 mm |
| Dimension | 74 mm \times 74 mm \times 80.1 mm (2.9" \times 2.9" \times 3.2") |
| Weight | < 600 g (1.3 lb.) |
| Ingress protection | IP40 (with lens and cables correctly installed) |
| Temperature | Working temperature: 0 $^{\circ}\text{C}$ to 50 $^{\circ}\text{C}$ (32 $^{\circ}\text{F}$ to 122 $^{\circ}\text{F}$) Storage temperature: -30 $^{\circ}\text{C}$ to 70 $^{\circ}\text{C}$ (-22 $^{\circ}\text{F}$ to 158 $^{\circ}\text{F}$) |
| Humidity | 20% to 95% RH, without condensation |
| General | |
| Client software | MVS or third-party software meeting with GigE Vision Protocol |
| Operating system | 32/64-bit Windows XP/7/10, 32/64-bit Linux, 64-bit MacOS |
| Compatibility | GigE Vision, GenICam |
| Certification | CE, FCC, RoHS, KC |