

CyberPower

User's Manual

SM30KPMX
SM180KMFY
SM300KMFY
SM600KMFY

Safety Precautions

This manual contains information concerning the installation and operation of Modular UPS. Please carefully read this manual prior to installation.

The Modular UPS cannot be put into operation until it is commissioned by engineers approved by the manufacturer (or its agent). Not doing so could result in personnel safety risk, equipment malfunction and invalidation of warranty.

Safety Message Definition

Danger: Serious human injury or even death may be caused, if this requirement is ignored.



Warning: Human injury or equipment damage may be caused, if this requirement is ignored.

Attention: Equipment damage, loss of data or poor performance may be caused, if this requirement is ignored.





Commissioning Engineer: The engineer who installs or operates the equipment should be well trained in electricity and safety and familiar with the operation, debug, and maintenance of the equipment.

Warning Label



The warning label indicates the possibility of human injury or equipment damage, and advises the proper step to avoid the danger. In this manual, there are three types of warning labels as below.

Labels	Description
 Danger	Serious human injury or even death may be caused, if this requirement is ignored.
 Warning	Human injury or equipment damage may be caused, if this requirement is ignored.
 Attention	Equipment damage, loss of data or poor performance may be caused, if this requirement is ignored.



Safety Instruction

 Danger	<ul style="list-style-type: none"> ◇ Performed only by commissioning engineers. ◇ This UPS is designed for commercial and industrial applications only, and is not intended for any use in life-support devices or system.
 Warning	<ul style="list-style-type: none"> ◇ Read all the warning labels carefully before operation, and follow the instructions.
	<ul style="list-style-type: none"> ◇ When the system is running, do not touch the surface with this label, to avoid any hurt of scald.
	<ul style="list-style-type: none"> ◇ ESD sensitive components inside the UPS, anti-ESD measure should be taken before handling.

Move & Install

 Danger	<ul style="list-style-type: none"> ◇ Keep the equipment away from heat source or air outlets. ◇ In case of fire, use dry powder extinguisher only, any liquid extinguisher can result in electric shock.
 Warning	<ul style="list-style-type: none"> ◇ Do not start the system if any damage or abnormal parts founded. ◇ Contacting the UPS with wet material or hands may be subject to electric shock.
 Attention	<ul style="list-style-type: none"> ◇ Use proper facilities to handle and install the UPS. Shielding shoes, protective clothes and other protective facilities are necessary to avoid injury. ◇ During positioning, keep the UPS way from shock or vibration. ◇ Install the UPS in proper environment, more detail in section 3.3.

Debug & Operate

 Danger	<ul style="list-style-type: none"> ◇ Make sure the grounding cable is well connected before connecting the power cables, the grounding cable and neutral cable must be in accordance with the local and national codes practice. ◇ Before moving or re-connecting the cables, make sure to cut off all the input power sources, and wait for at least 10 minutes for internal discharge. Use a multi-meter to measure the voltage on terminals and ensure the voltage is lower than 36V before operation.
 Attention	<ul style="list-style-type: none"> ◇ The earth leakage current of load will be carried by RCCB or RCD. ◇ Initial check and inspection should be performed after long time storing of UPS.

Maintenance & Replacement

 Danger	<ul style="list-style-type: none"> ◇ All the equipment maintenance and servicing procedures involving internal access need special tools and should be carried out only by trained personnel. The components that can only be accessed by opening the protective cover with tools cannot be maintained by user. ◇ This UPS full complies with "IEC62040-1-1-General and safety requirements for use in operator access area UPS". Dangerous voltages are present within the battery box. However, the risk of contact with these high voltages is minimized for non-service personnel. Since the component with dangerous voltage can only be touched by opening the protective cover with a tool, the possibility of touching high voltage component is minimized. No risk exists to any personnel when operating the equipment in the normal manner, following the recommended operating procedures
---	---

	in this manual.
--	-----------------

Battery Safety

 <p>Danger</p>	<ul style="list-style-type: none"> ✧ All the battery maintenance and servicing procedures involving internal access need special tools or keys and should be carried out only by trained personnel. ✧ When connected together, the battery terminal voltage will exceed 400Vdc and is potentially lethal. ✧ Battery manufacturers supply details of the necessary precautions to be observed when working on, or in the vicinity of, a large bank of battery cells. These precautions should be followed implicitly at all times. Particular attention should be paid to the recommendations concerning local environmental conditions and the provision of protective clothing, first aid and fire-fighting facilities. ✧ Ambient temperature is a major factor in determining the battery capacity and life. The nominal operating temperature of battery is 20°C. Operating above this temperature will reduce the battery life. Periodically charge the battery according to the battery user manuals to ensure the back-up time of UPS. ✧ Replace the batteries only with the same type and the same number, or it may cause explosion or poor performance. ✧ When connecting the battery, follow the precautions for high-voltage operation before accepting and using the battery, check the appearance the battery. If the package is damaged, or the battery terminal is dirty, corroded or rusted or the shell is broken, deformed or has leakage, replace it with new product. Otherwise, battery capacity reduction, electric leakage or fire may be caused. <ul style="list-style-type: none"> ● Before operating the battery, remove the finger ring, watch, necklace, bracelet and any other metal jewelry ● Wear rubber gloves. ● Eye protection should be worn to prevent injury from accidental electrical arcs. ● Only use tools (e.g. wrench) with insulated handles. ● The batteries are very heavy. Please handle and lift the battery with proper method to prevent any human injury or damage to the battery terminal. ● Do not decompose, modify or damage the battery. Otherwise, battery short circuit, leakage or even human injury may be caused. ● The battery contains sulfuric acid. In normal operation, all the sulfuric acid is attached to the separation board and plate in the battery. However, when the battery case is broken, the acid will leak from the battery. Therefore, be sure to wear a pair of protective glasses, rubber gloves and skirt when operating the battery. Otherwise, you may become blind if acid enters your eyes and your
--	---

Safety Precautions

	<p>skin may be damaged by the acid.</p> <ul style="list-style-type: none">● At the end of battery life, the battery may have internal short circuit, drain of electrolytic and erosion of positive/negative plates. If this condition continues, the battery may have temperature out of control, swell or leak. Be sure to replace the battery before these phenomena happen.● If a battery leaks electrolyte, or is otherwise physically damaged, it must be replaced, stored in a container resistant to sulfuric acid and disposed of in accordance with local regulations.● If electrolyte comes into contact with the skin, the affected area should be washed immediately with water.
--	--

Disposal

 Warning	◇ Dispose of used battery according to the local instructions
--	---

Contents

Safety Precautions.....	III
Chapter 1 Product Introduction.....	1
1.1 System Configuration.....	1
1.2 Power Module	2
1.3 Operation Mode.....	2
1.3.1 Normal Mode.....	2
1.3.2 Battery Mode.....	2
1.3.3 Bypass Mode	3
1.3.4 Maintenance Mode (Manual Bypass).....	3
1.3.5 ECO Mode	4
1.3.6 Auto-restart Mode.....	4
1.3.7 Frequency Converter Mode	5
1.4 UPS Structure.....	5
1.4.1 UPS Configuration	5
1.4.2 UPS Outlook	5
Chapter 2 Installation Instruction.....	9
2.1 Location.....	9
2.1.1 Installation Environment.....	9
2.1.2 Site Selection	9
2.1.3 Size and Weight.....	9
2.2 Unloading and Unpacking	11
2.2.1 Moving and Unpacking of the Cabinet.....	11
2.2.2 Unpacking Power Module.....	12
2.3 Positioning	13
2.3.1 Positioning Cabinet	13
2.3.2 Installing Power Module.....	15
2.4 Battery	16
2.5 Cable Entry	16
2.6 Power Cables	19
2.6.1 Specifications	19
2.6.2 Specifications for Power Cables Terminal	19
2.6.3 Circuit Breaker	20
2.6.4 Connecting Power Cables	20
2.7 Control and Communication Cables.....	22
2.7.1 Dry Contact Interface	23
2.7.2 Communication Interface	28
Chapter 3 LCD Panel.....	29
3.1 Introduction.....	29
3.2 LCD panel for Power Module.....	29
3.2.1 LED Indicator	29
3.2.2 Control and Operation Keys	30
3.2.3 LCD Display	30
3.3 UPS operator panel.....	32
3.3.1 LED Indicator	32
3.3.2 Control and Operation Keys	33
3.3.3 LCD touch Screen.....	34
3.4 Main Menu	35
3.4.1 Cabinet.....	35
3.4.2 Module.....	37
3.4.3 Setting	39
3.4.4 Log	41

3.4.5 Operate	45
3.4.6 Scope	46
Chapter 4 Operations	48
4.1 UPS Start-up	48
4.1.1 Start in Normal Mode	48
4.1.2 Start from Battery	49
4.2 Procedure for Switching between Operation Modes.....	49
4.2.1 Switching the UPS from Normal Mode into Battery Mode.....	49
4.2.2 Switching the UPS from Normal Mode into Bypass Mode	49
4.2.3 Switching the UPS into Normal Mode from Bypass Mode	50
4.2.4 Switching the UPS from Normal Mode into Maintenance Bypass Mode	50
4.2.5 Switching the UPS into Normal Mode from Maintenance Bypass Mode	51
4.3 Battery Maintenance	51
4.4 EPO	52
4.5 Installation of Parallel Operation System.....	53
Chapter 5 Maintenance	55
5.1 Precautions.....	55
5.2 Instruction for Maintaining Power Module.....	55
5.3 Instruction for Maintaining	55
5.3.1 Maintaining Bypass Module for 6-slot and 10-slot Cabinet	55
5.3.2 Maintaining Static Bypass Unit for 20-slot Cabinet	56
5.3.3 Maintenance for the Air-drawing fans	56
5.3.4 Battery Maintenance	56
5.3.5 Disconnect the Inner Control Neutral cable.....	57
5.4 Battery Setting.....	57
5.4.1 Setting of Battery Type.....	58
5.4.2 Setting of Battery Number.....	58
5.4.3 Battery Capacity Setting	58
5.4.4 Float and Boost Charge Setting.....	58
5.4.5 EOD Voltage Setting	59
5.4.6 Charging Current Percent Limit	59
5.4.7 Battery Temperature Compensate	59
5.4.8 Boost Charge Time Limit.....	59
5.4.9 Auto Boost Period	59
5.4.10 Auto maintenance Discharge Period	59
5.4.11 Warnings for Battery and Environment Temperature Overheat.....	60
5.5 Replacing Dust Filter (optional)	60
6.1 Applicable Standards	61
6.2 Environmental Characteristics.....	61
6.3 Mechanical Characteristic	61
6.4 Electrical Characteristics	62
6.4.1 Electrical Characteristics (Input Rectifier).....	62
6.4.2 Electrical Characteristics (Intermediate DC Link).....	63
6.4.3 Electrical Characteristics (Inverter Output).....	63
6.4.4 Electrical Characteristics (Bypass Mains Input)	64
6.5 Efficiency.....	64
6.6 Display and Interface	64
Chapter 7. Contacts.....	65

Chapter 1 Product Introduction

1.1 System Configuration

The Modular UPS is configured by the following part: Power modules, Bypass & Monitoring module, and cabinet with manual Bypass switch. One or several battery strings should be installed to provide backup energy once the utility fails. The UPS structure is shown in Fig. 1-1.

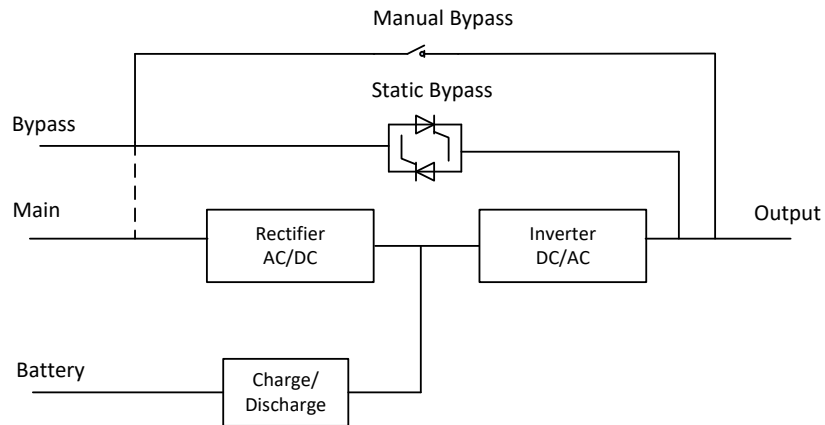

Fig.1-1 6-slot and 10-slot UPS Configuration

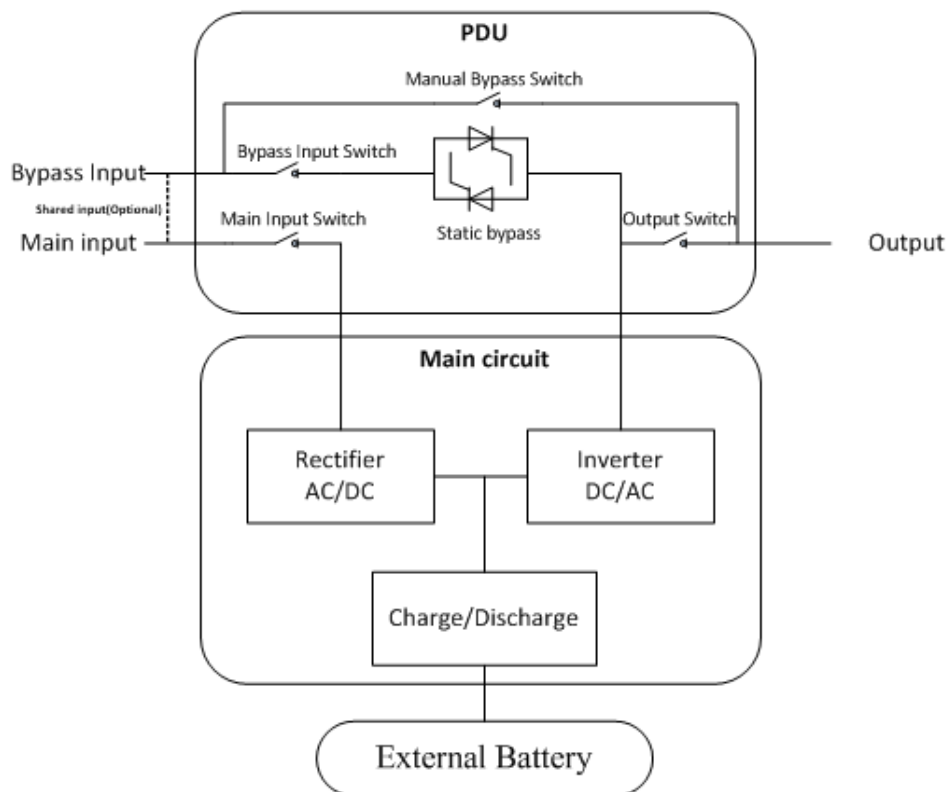

Fig.1-2 20-slot UPS Configuration

1.2 Power Module

The power module structure is shown as Fig.1-3. The power module contains a rectifier, an inverter, and a DC/DC converter for charge and discharge of the external batteries.

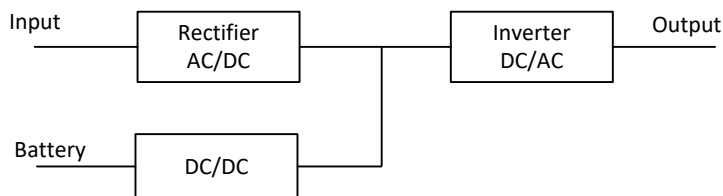

Fig 1-3 Power module structure

1.3 Operation Mode

The Modular UPS is an on-line, double-conversion UPS that permits operation in the following modes:

- Normal mode
- Battery mode
- Bypass mode
- Maintenance mode (manual bypass)
- ECO mode
- Auto-restart mode
- Frequency Converter mode

1.3.1 Normal Mode

The inverter of power modules continuously supply the critical AC load. The rectifier/charger derives power from the AC mains input source and supplies DC power to the inverter while simultaneously FLOAT or BOOST charging its associated backup battery.

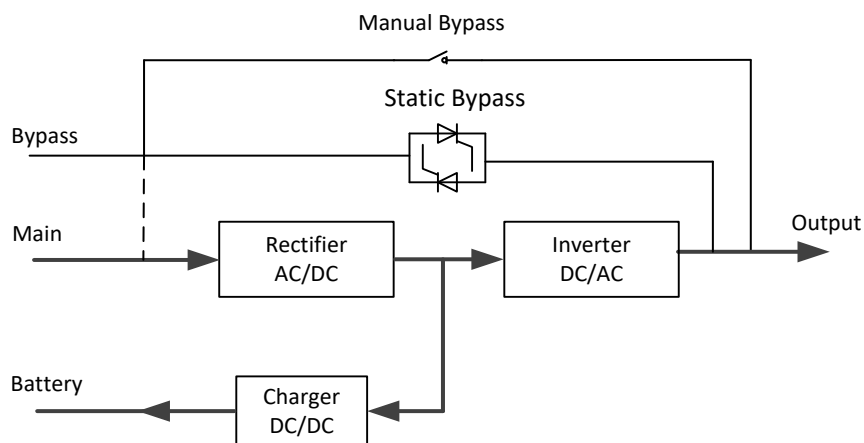

Fig.1-4 Normal mode operation diagram

1.3.2 Battery Mode

Upon failure of the AC mains input power, the inverter of power modules, which obtain power from the battery, supply the critical AC load. There is no interruption in power to the critical load upon failure. After restoration of the AC mains input power, the "Normal mode" operation will continue automatically without the necessity of user intervention.

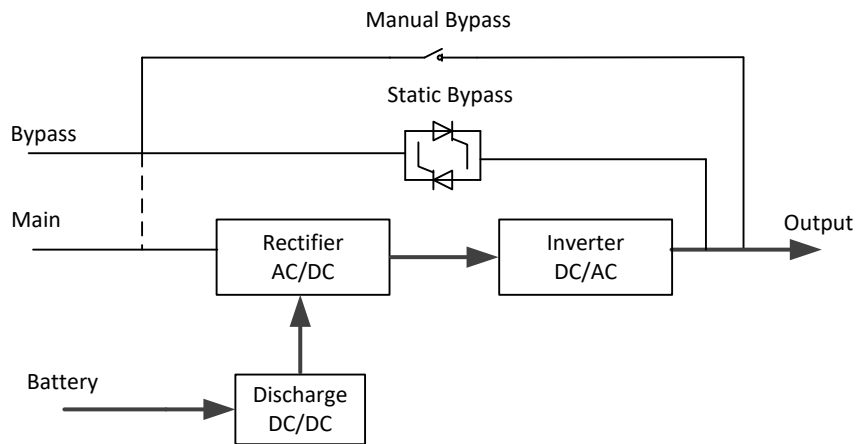

Fig.1-5 Battery mode operation diagram

1.3.3 Bypass Mode

If the inverter overload capacity is exceeded under Normal mode, or if the inverter becomes unavailable for any reason, the static transfer switch will perform a transfer of the load from the inverter to the bypass source, with no interruption in power to the critical AC load. Should the inverter be asynchronous with the bypass, the static switch will perform a transfer of the load from the inverter to the bypass with power interruption to the load. This is to avoid large cross currents due to the paralleling of unsynchronized AC sources. This interruption is programmable but typically set to be less than 3/4 of an electrical cycle, e.g., less than 15ms (50Hz) or less than 12.5ms (60Hz). The action of transfer/re-transfer can also be done by the command through monitor.

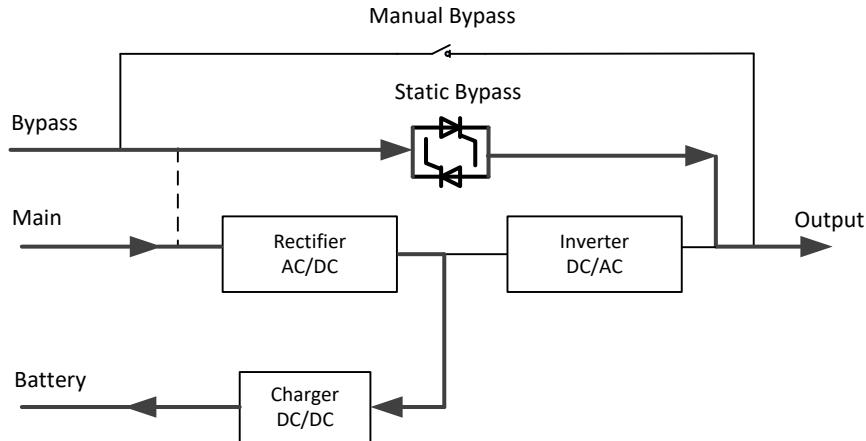

Fig.1-6 Bypass mode operation diagram

1.3.4 Maintenance Mode (Manual Bypass)

A manual bypass switch is available to ensure continuity of supply to the critical load when the UPS becomes unavailable e.g. during a maintenance procedure. (See Fig.1-7).

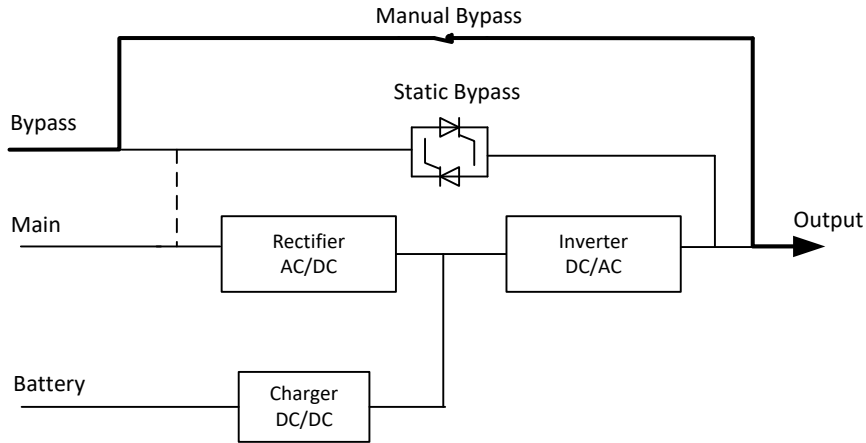

Fig.1-7 Maintenance mode operation diagram



Danger

During Maintenance mode, dangerous voltages are present on the terminal of input, output and neutral, even with all the modules and the LCD turned off.

1.3.5 ECO Mode

To improve system efficiency, UPS rack system works in Bypass mode at normal time, and inverter is standby. When the utility fails, the UPS transfers to Battery Mode and the inverter provide powers to the loads.

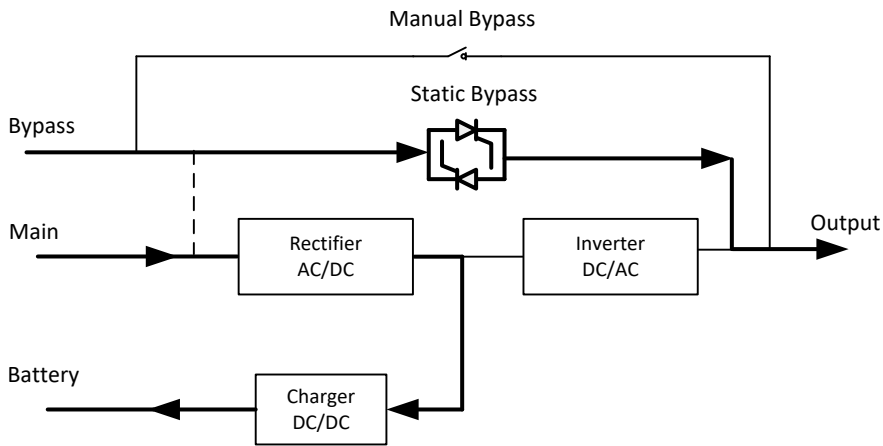

Fig.1-8 ECO Mode operation diagram



Note

There is a short interruption time (less than 10ms) when transfer from ECO mode to battery mode, it must be sure that the interruption has no effect on loads.

1.3.6 Auto-restart Mode

The battery may become exhausted following an extended AC mains failure. The inverter shuts down when the battery reaches the End of Discharge Voltage (EOD). The UPS may be programmed to “System Auto Start Mode after EOD”. The system starts

after a delay time when the AC main recovers. The mode and the delay time are programmed by the commissioning engineer.

1.3.7 Frequency Converter Mode

By setting the UPS to Frequency Converter mode, the UPS could present a stable output of fixed frequency (50 or 60Hz), and the bypass static switch is not available.

1.4 UPS Structure

1.4.1 UPS Configuration

The UPS configuration is provided in Table 1.1

Table1.1 UPS Configuration

Item	Components	Quantity/ pcs	Remark
6-slot Cabinet	Manual Bypass	1	Requisite, factory installed
	Bypass & Monitoring module	1	Requisite, factory installed
	Dust filter	1	Optional.
10-slot Cabinet	Manual Bypass		Requisite, factory installed
	Bypass & Monitoring module	1	Requisite, factory installed
	Dust filter	1	Optional.
20-slot Cabinet	Power distribution cabinet (CB of Input, Bypass Input, Output and Manual Bypass)	1	Requisite, factory installed
	Monitoring unit	1	Requisite, factory installed
	Bypass unit	1	Requisite, factory installed
	Dust filter	1	Optional
30 kVA Power module	Power module	1-20	Requisite, installed on site.

1.4.2 UPS Outlook

The UPS outlook is shown as Fig.1-9 to Fig.1-11.

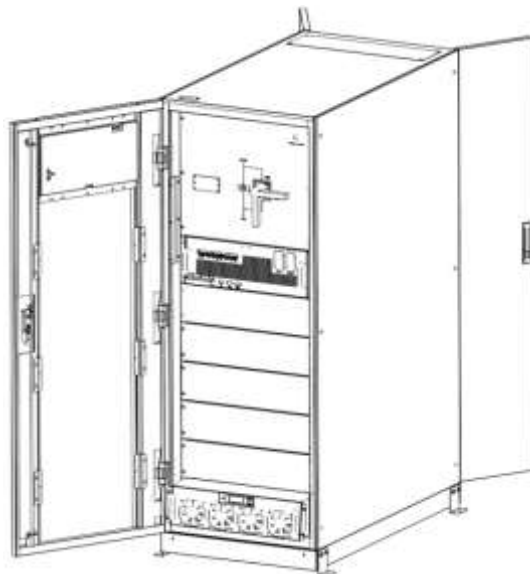

Fig.1-9 Outlook of 6-slot UPS

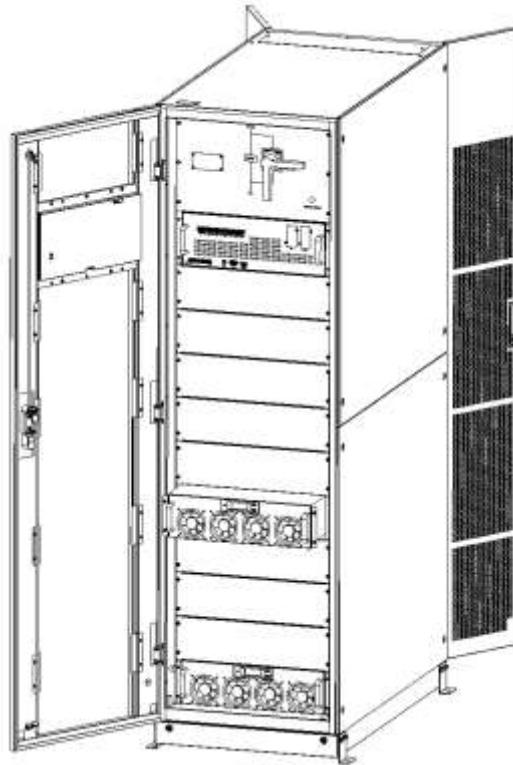

Fig.1-10 Outlook of 10-slot UPS

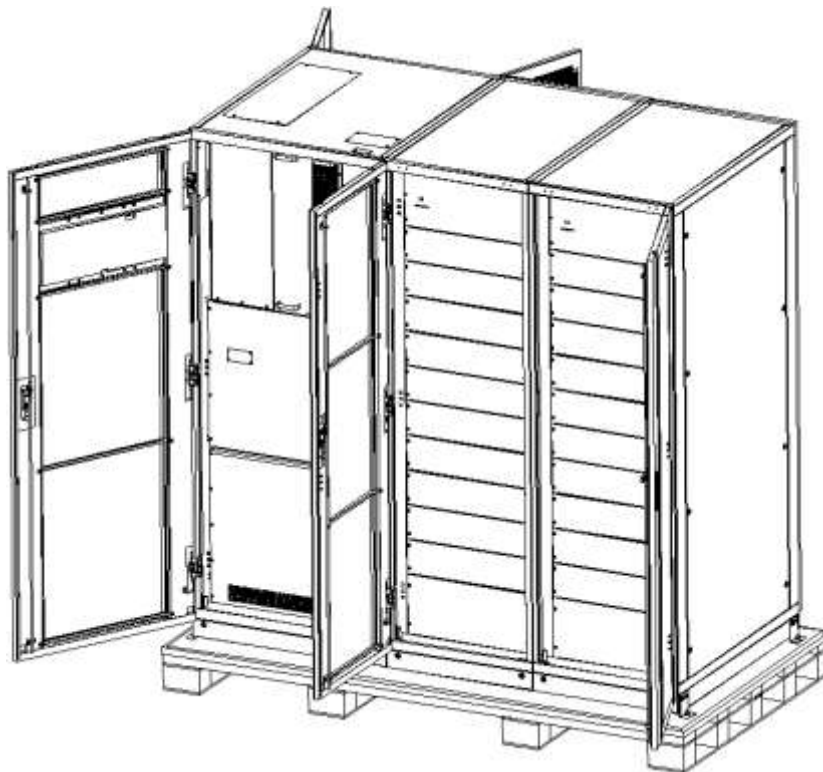

Fig.1-11 Outlook of 20-slot UPS

The UPS front view are shown in Fig.1-12 to Fig. 1-14

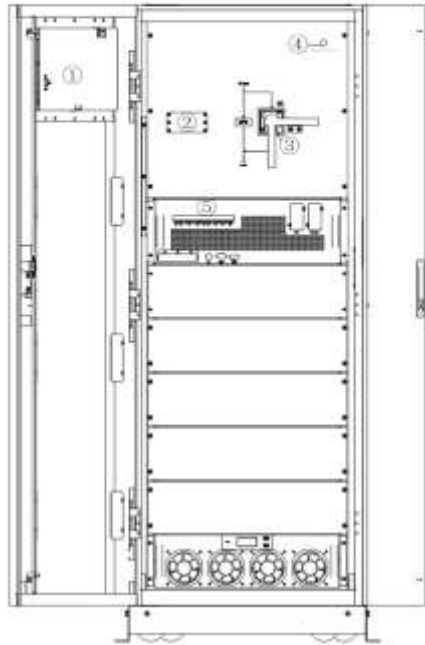

Fig.1-12 Front view of 6-slot UPS

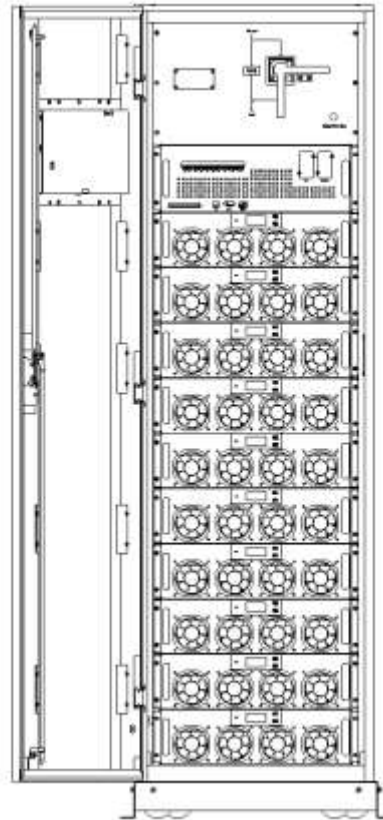

Fig. 1-13 Front view of 10-slot UPS

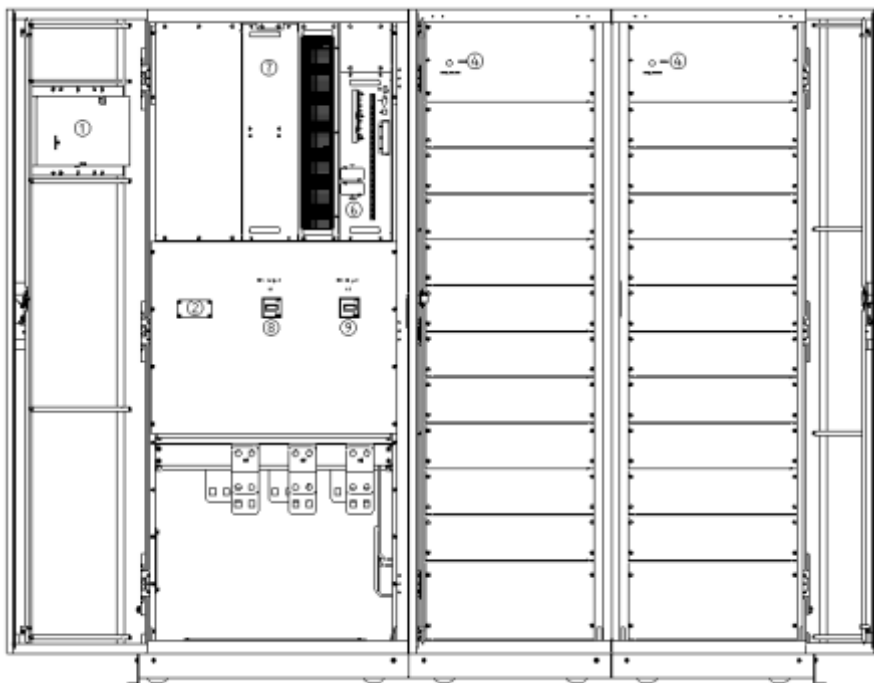

Fig. 1-14 Front view of 20-slot UPS

- ① LCD control panel; ② SPD; ③ Manual Bypass switch ④ Battery cold start;
 ⑤ Monitoring & static bypass module; ⑥ Monitoring unit; ⑦ Static Bypass unit;
 ⑧ Output switch of 20-slot cabinet Q3; ⑨ Input switch of 20-slot cabinet Q1
 The UPS back view are shown in Fig.2-15 to Fig.2-17.

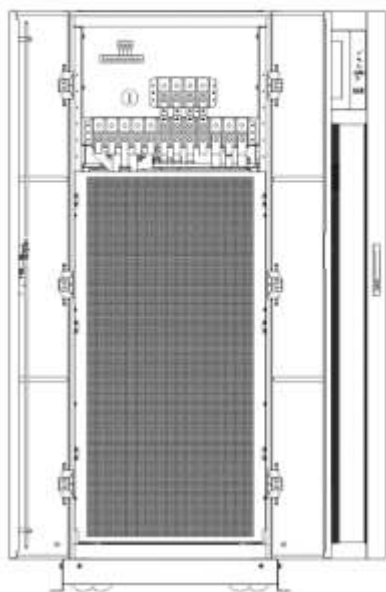

Fig. 1-15 Back view of 6-slot UPS

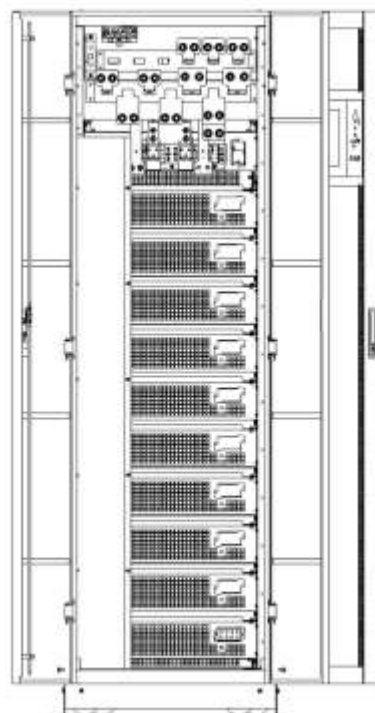

Fig. 1-16 Back view of 10-slot UPS

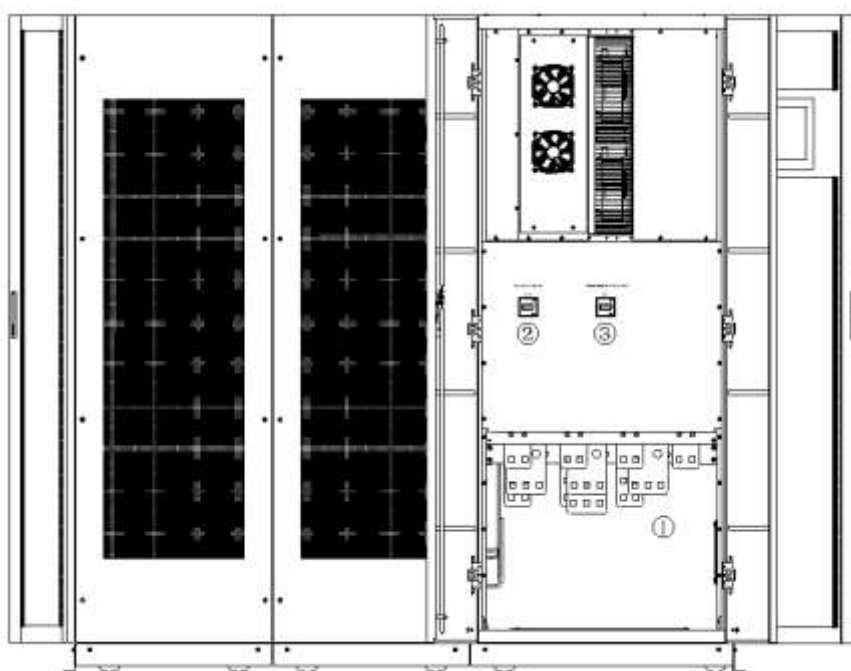

Fig. 1-17 Back view of 20-slot UPS

- ① PDU; ② Bypass Input switch of 20-slot cabinet Q3;
- ③ Manual bypass switch of 20-slot cabinet Q3

Chapter 2 Installation Instruction

2.1 Location

As each site has its requirements, the installation instructions in this section are to act as a guide for the general procedures and practices that should be observed by the installing engineer.

2.1.1 Installation Environment

The UPS is intended for indoor installation and uses forced convection cooling by internal fans. Please make sure there is enough space for the UPS ventilation and cooling.

Keep the UPS far away from water, heat and inflammable and explosive, corrosive material. Avoid installing the UPS in the environment with direct sunlight, dust, volatile gases, corrosive material and high salinity.

Avoid installing the UPS in the environment with conductive dirt.

The operating environment temperature for battery is 20°C to -25°C. Operating above 25°C will reduce the battery life, and operation below 20°C will reduce the battery capacity.

The battery will generate a little amount of hydrogen and oxygen at the end of charging; ensure the fresh air volume of the battery installation environment must meet EN50272-2001 requirements.

If external batteries are to be used, the battery circuit breakers (or fuses) must be mounted as close as possible to the batteries, and the connecting cables should be as short as possible.

2.1.2 Site Selection

Ensure the ground or installation platform can bear the weight of the UPS cabinet, batteries and battery rack.

No vibration and less than 5 degree inclination horizontally.

The equipment should be stored in a room so as to protect it against excessive humidity and heat sources.

The battery needs to be stored in dry and cool place with good ventilation. The most suitable storage temperature is 20 °C to 25°C.

2.1.3 Size and Weight

Ensure there is enough space for the placement of the UPS. The room reserved for the UPS cabinet is shown in 2-1.



Attention

Ensure the following space margin: at least 0.8m before the front of the 6-slot or the 10-slot cabinet, at least 1 m for the 20-slot cabinet, so as to easily maintain the power module with the front door fully open; at least 0.5m at behind of 6-slot or the 10-slot cabinet, at least 0.6 m for 20-slot cabinet for ventilation and cooling. The space reserved for the cabinet is shown in Fig.3-2.

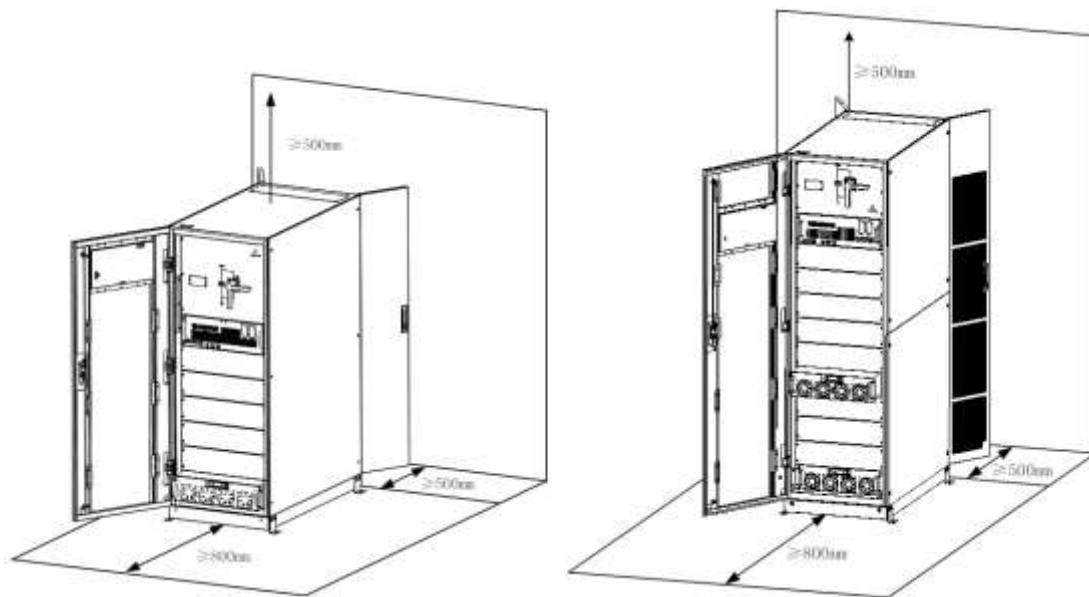

(a.) 6-slot cabinet

(b.) 10-slot cabinet

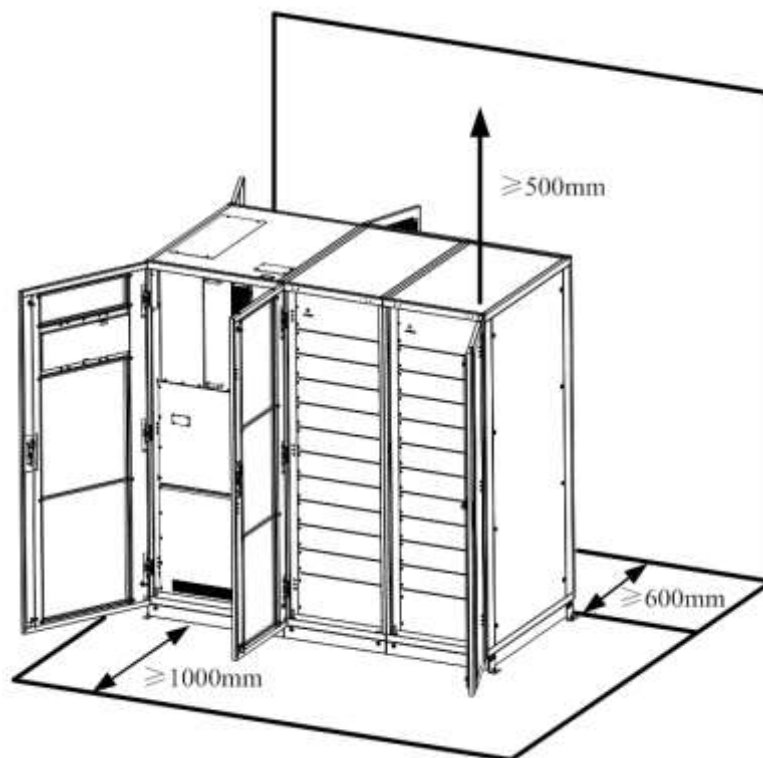

(c.) 20-slot cabinet

Fig.2-1 Space reserved for the cabinet (Unit : mm)

The dimension and weight for the UPS cabinet is shown in Table 2.1

Table 2.1 Weight for the cabinet

Configuration	Dimension(W×D×H)(mm)	Weight(Kg)
6-slot Cabinet (with bypass module)	600×1100×1600	170

10-slot Cabinet (with bypass module)	600×1100×2000	220
20-slot Cabinet (with bypass module)	2000×1100×2000	620
30KVA power module	460×790×133	34

2.2 Unloading and Unpacking

2.2.1 Moving and Unpacking of the Cabinet

The steps to move and unpack the cabinet are as follows :

1. Check if any damages to the packing. (If any, contact to the carrier)
2. Transport the equipment to the designated site by forklift, as shown in Fig.2-2.

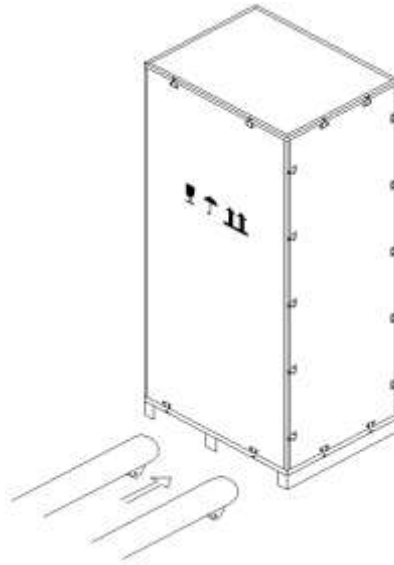

Fig.2-2 Transport to the designated site

3. Open the top plate of the steel-edged wooden case with slotted awl and pier, followed by side boards (see Fig.2-3)..

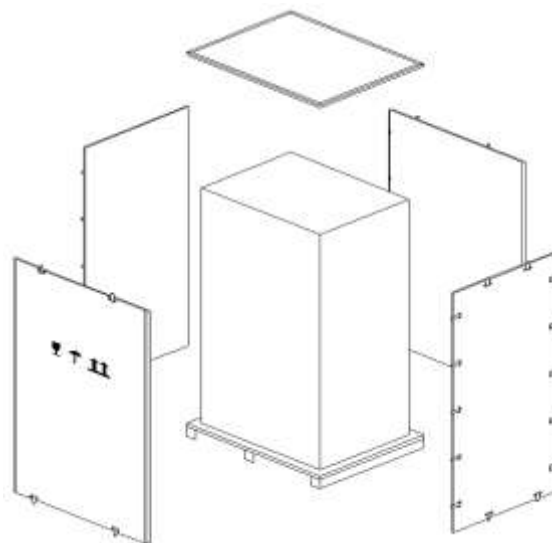

Fig.2-3 Disassemble the case

4. Remove the protective foam around the cabinet.

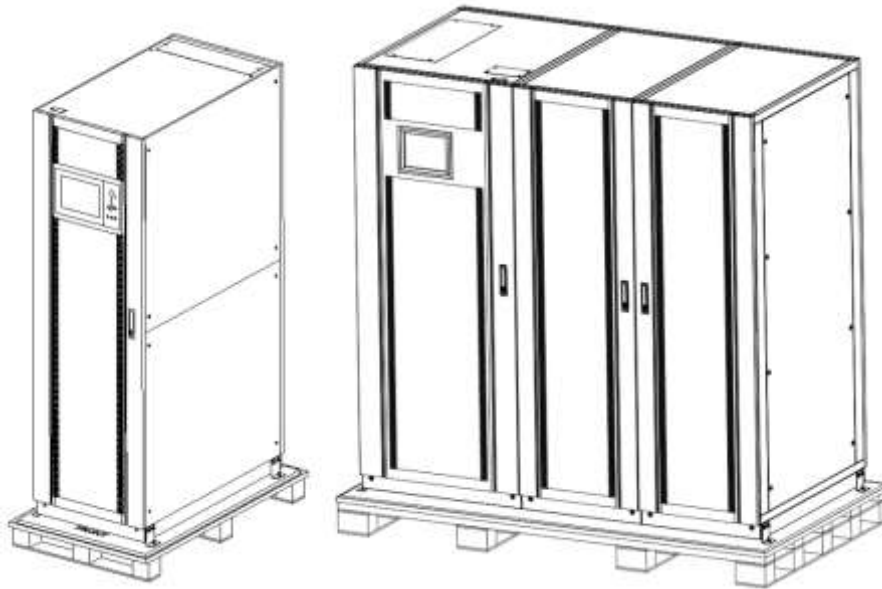

Fig.2-4 Remove the protective foam

5. Check the UPS.
 - (a) Visually examine if there are any damages to UPS during transportation. If any, contact to the carrier.
 - (b) Check the UPS with the list of the goods. If any items are not included in the list, contact to our company or the local office.
6. Dismantle the bolt that connects the cabinet and wooden pallet after disassembly.
7. Move the cabinet to the installation position.



Attention

Be careful while removing to avoid scratching the equipment.

2.2.2 Unpacking Power Module

1. The steps to move and unpack the power module are as follows
2. The packing case must be placed on the platform smoothly, as is shown in Fig.3-5

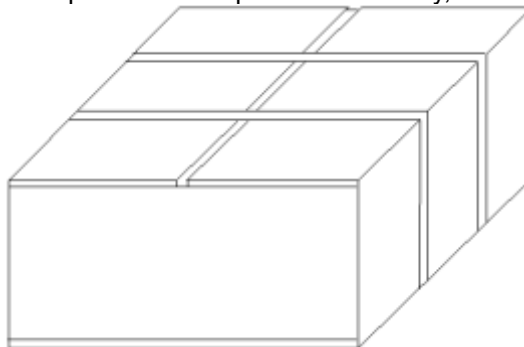

Fig.2-5 Place on platform smoothly

3. Cut the plastic packing belt and scotch tape to open the carton.

(see Fig.2-6) .

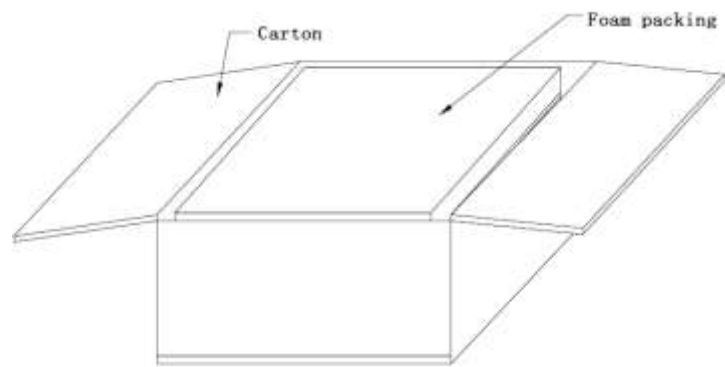

Fig.2-6 Open the carton

4. Remove the foam cover (See Fig.2-7).

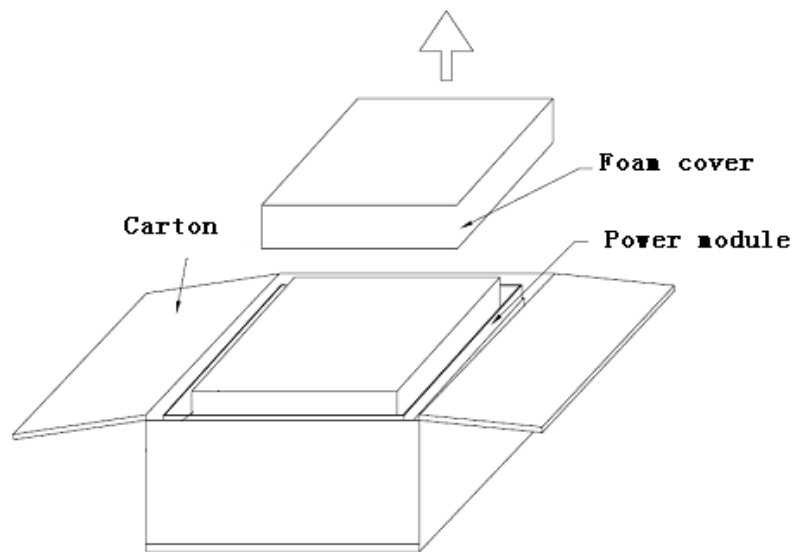

Fig.2-7 Remove the foam cover

5. Take out the UPS with plastic package and dismantle the packaging materials.



Attention

The waste materials of unpacking should be disposed to meet the demand for environmental protection.

2.3 Positioning

2.3.1 Positioning Cabinet

The UPS cabinet has two way of supporting itself: One is to support itself temporarily by the 4 wheels at the bottom(12 for the 20-slot) , making it convenient to adjust the position of the cabinet ; The other is by anchor bolts to support the cabinet permanently after adjusting the position of the cabinet. The supporting structure is shown in Fig. 2-8..

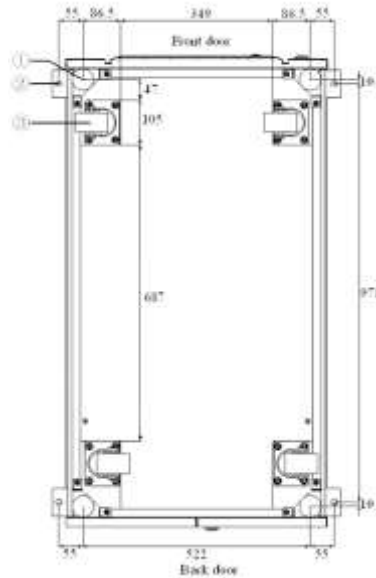

(a.) 6&10-slot cabinet

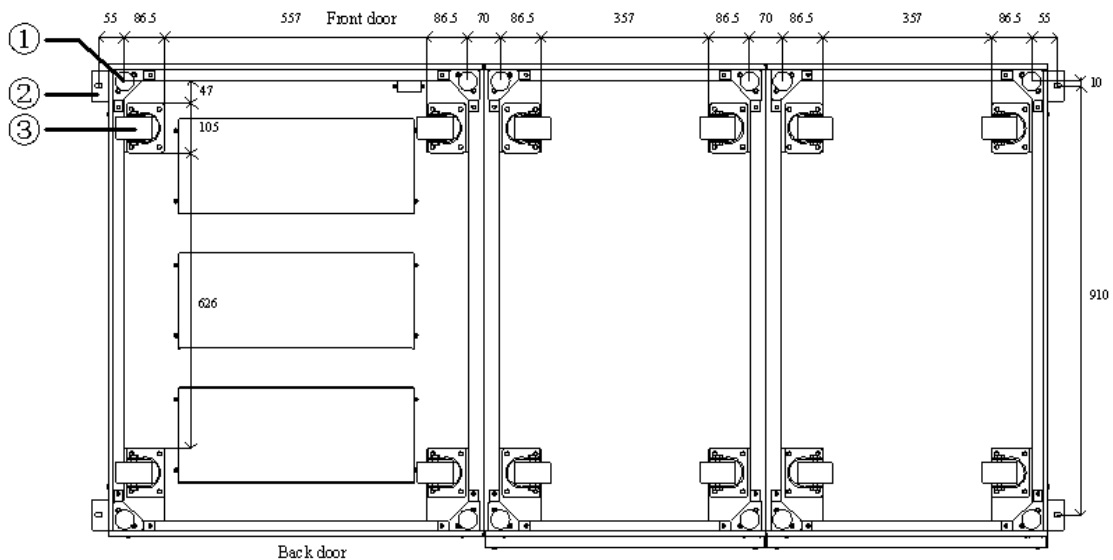

(b.) 20-slot cabinet

① Adjustable anchor bolt ② L-shape corner fittings ③ supporting wheels

Fig.2-8 Supporting structure (Bottom view)

The steps to position the cabinet are as follows :

1. Ensure the supporting structure is in good condition and the mounting floor is smooth and strong.
2. Retract the anchor bolts by turning them counterclockwise using wrench, the cabinet is then supported by the four wheels.
3. Adjust the cabinet to the right position by the supporting wheels.
4. Put down the anchor bolts by turning them clockwise using wrench, the cabinet is then supported by the four anchor bolts.
5. Ensure the four anchor bolts are in the same height and the cabinet is fixed and immovable.
6. Positioning done.

**Attention**

Auxiliary equipment is needed when the mounting floor is not solid enough to support the cabinet, which helps distribute the weight over a larger area. For instance, cover the floor with iron plate or increase the supporting area of the anchor bolts.

2.3.2 Installing Power Module

The installation position of power module is shown in Fig.2-10 .Please install the power modules following the principle of from bottom to top to prevent inclination of the cabinet due to high center of gravity. The steps of installing power module are as follows (Take the 10-slot cabinet as example):

1. Ensure the cabinet is fixed and no damage to the body and inserting port of the power module.
2. Hold the handler and the body of the power module by two persons at each side.
3. Insert the module in the installation position, and push it into the cabinet smoothly.
4. Fix the module to the cabinet through the mounting holes on two sides of the front plate of the module (See Fig.2-9 at right).
5. Installing Power Module done.

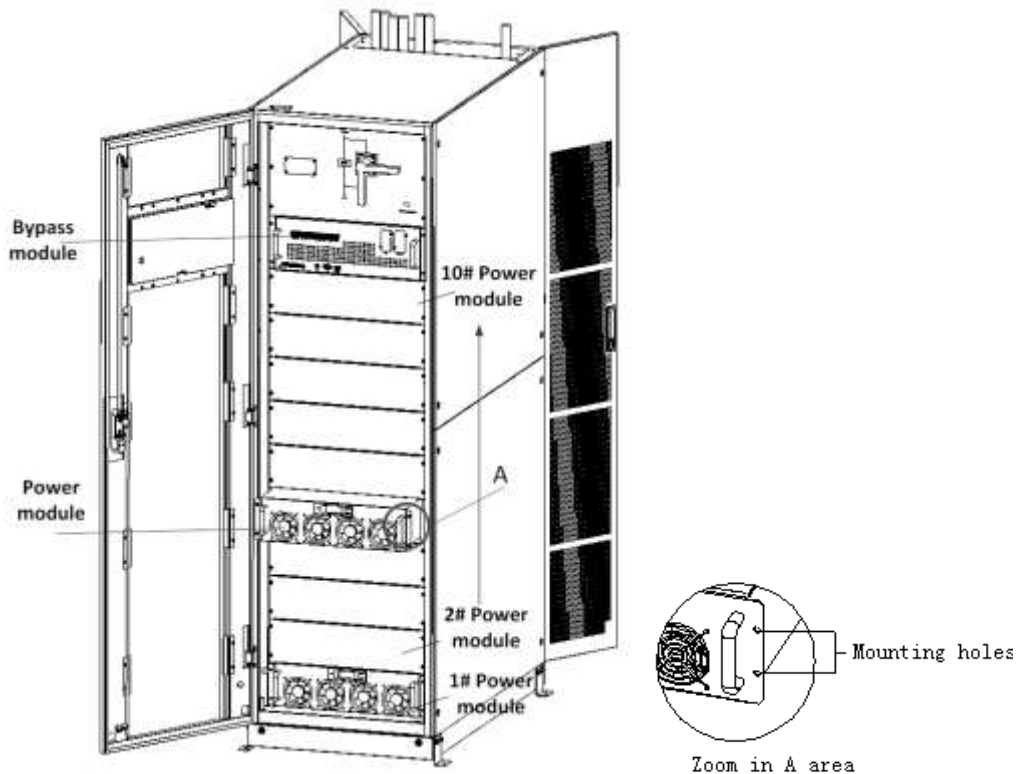

Fig.2-9 Installing power module

**Note**

The installing method of bypass module for 6-slot and 10-slot is the same as the power module.

The installing of Static Bypass Unit and Monitoring Unit for 20-slot cabinet needs to be split the inner cable and copper bars.



Attention

- Do not place the module on the floor by rear side with connectors;
- All installation works for bypass module and power module should be done by 2 persons together, for its heavy weight.

2.4 Battery

Three terminals (positive, neutral, negative) are drawn from the battery unit and connected to UPS system. The neutral line is drawn from the middle of the batteries in series (See Fig.2-9).

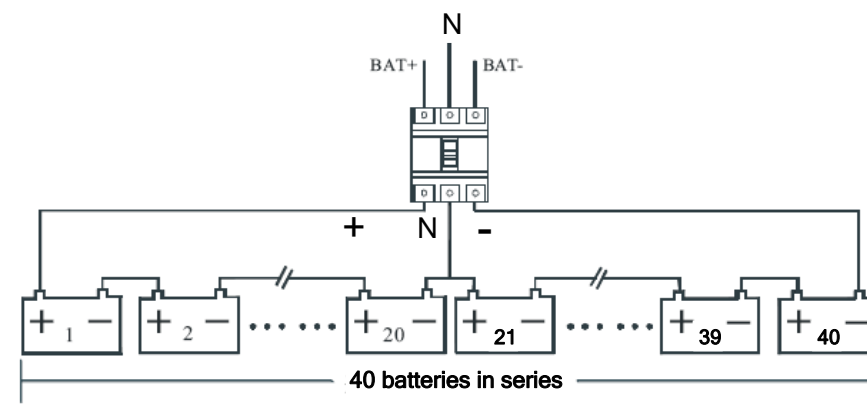

Fig.2-9 Battery string wiring diagram



Danger

The battery terminal voltage is of more than 400Vdc, please follow the safety instructions to avoid electric shock hazard.

Ensure the positive, negative, neutral electrode is correctly connected from the battery unit terminals to the breaker and from the breaker to the UPS system.

2.5 Cable Entry

For the 6-slot and 20-slot cabinet, both bottom and top cable entry are available.

For the 10-slot cabinet, the top cable entry is available. However, if bottom cable entry is required, optional parts should be added.

The cable entry are shown in Fig.3-10, Fig.3-11 and Fig.3-12

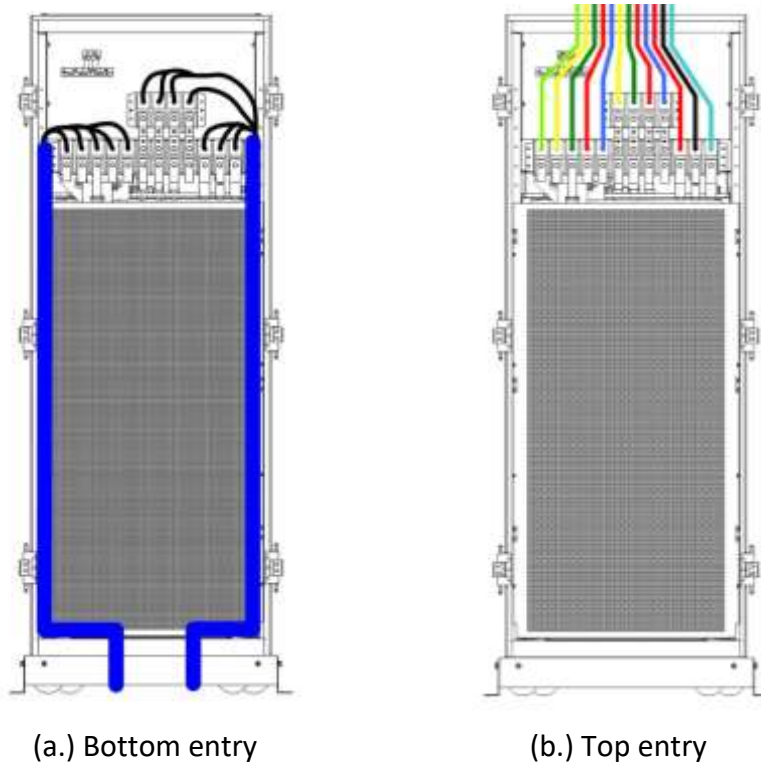

Fig.2-10 Cable entry for 6-slot cabinet

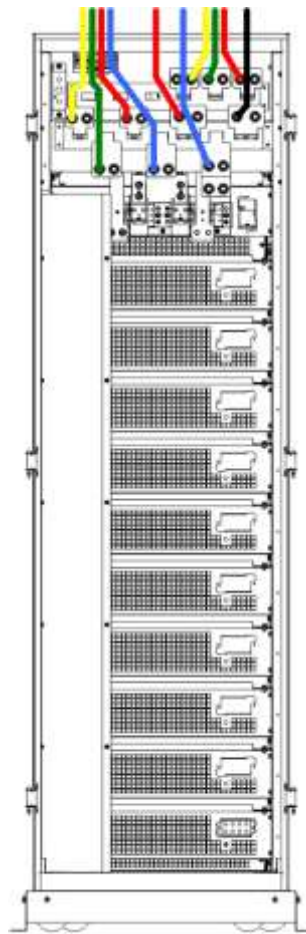
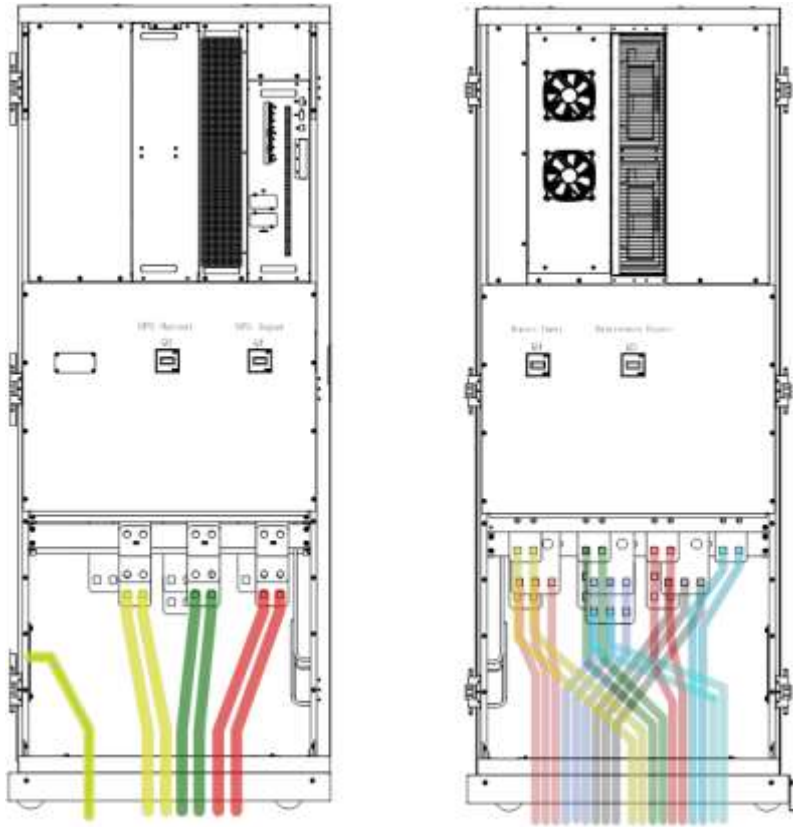
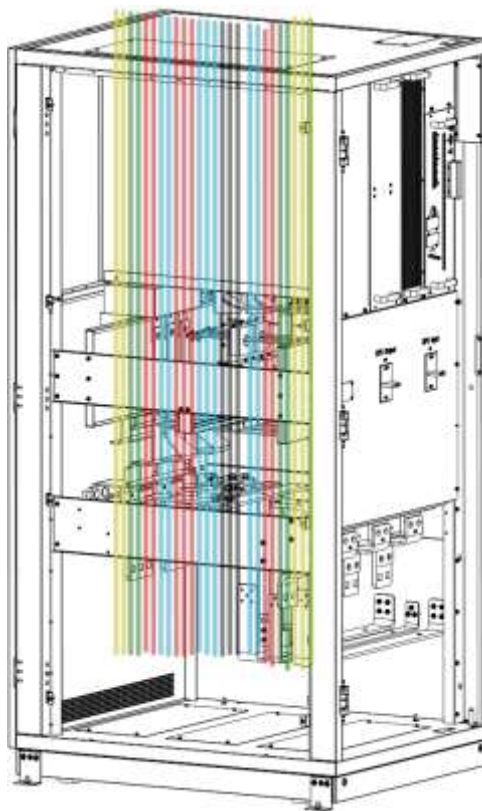

Fig.3-11 Top entry for 10-slot cabinet



Bottom entry



Top entry

Fig.3-12 Cable entry for 20-slot cabinet

2.6 Power Cables

2.6.1 Specifications

The UPS power cables are recommended in Table 2.2.

Table 2.2 Recommended cables for power cables

Contents			150/25	180/30	250/25	300/30	500/25	600/30
Main Input	Cable (mm ²)	A	70	95	150	185	2*150	2*185
		B	70	95	150	185	2*150	2*185
		C	70	95	150	185	2*150	2*185
		N	70	95	150	185	2*150	2*185
Output	Cable (mm ²)	A	70	70	120	150	2*120	2*150
		B	70	70	120	150	2*120	2*150
		C	70	70	120	150	2*120	2*150
		N	70	70	120	150	2*120	2*150
Bypass Input (Optional)	Cable (mm ²)	A	70	70	120	150	2*120	2*150
		B	70	70	120	150	2*120	2*150
		C	70	70	120	150	2*120	2*150
		N	70	70	120	150	2*120	2*150
Battery	Cable (mm ²)	+	95	95	185	240	2*185	2*240
		-	95	95	185	240	2*185	2*240
		N	95	95	185	240	2*185	2*240
PE	Cable (mm ²)	PE	70	70	95	95	120	120



Note

The recommended cable section for power cables are only for situations described below :

- Ambient temperature : 30°C.
- AC loss less than 3% , DC loss less than 1% , The length of the AC power cables are no longer than 50 m and the length of the DC power cables are no longer than 30 m.
- Currents listed in the table are based on the 380V system (Line-to-line voltage) .For 400 V system, the currents is 0.95 times and for the 415V system the current is 0.92 times.
- The size of neutral lines should be 1.5~1.7 times the value listed above when the predominant load is non-linear.

2.6.2 Specifications for Power Cables Terminal

Specifications for power cables connector are listed as Table 2.3.

Table 2.3 Requirements for power module terminal

Model	Terminal	Connection	Bolt	Bolt Aperture	Torque
6-slot cabinet	Main Input	Cables crimped OT terminal	M10	/	15Nm
	Bypass Input	Cables crimped OT terminal	M10	/	15Nm
	Battery	Cables crimped OT terminal	M10	/	15Nm
	Output	Cables crimped OT terminal	M10	/	15Nm
	PE	Cables crimped OT terminal	M10	/	15Nm
10-slot cabinet	Main Input	Cables crimped OT terminal	M12	13mm	22Nm
	Bypass Input	Cables crimped OT terminal	M12	13mm	22Nm

	Battery	Cables crimped OT terminal	M12	13mm	22Nm
	Output	Cables crimped OT terminal	M12	13mm	22Nm
	PE	Cables crimped OT terminal	M12	13mm	22Nm
20-slot cabinet	Main Input	Cables crimped OT terminal	M16	17mm	96Nm
	Bypass Input	Cables crimped OT terminal	M16	17mm	96Nm
	Battery	Cables crimped OT terminal	M16	17mm	96Nm
	Output	Cables crimped OT terminal	M16	17mm	96Nm
	PE	Cables crimped OT terminal	M12	13mm	22Nm

2.6.3 Circuit Breaker

The circuit breakers (CB) for the system are recommended in Table 2.4.

Table 2.4 Recommended CB

Installed position	6-slot cabinet	10-slot cabinet	20-slot cabinet
Input CB	300A/3P	600A/3P	/
Bypass Input CB	250A/3P	500A/3P	/
Output CB	250A/3P	500A/3P	/
Battery CB	400A,500Vdc	800A,500Vdc	1250A,500Vdc



For the 20-slot cabinet, the Main Input, Bypass Input and Output CB are installed in the Cabinet.



Attention

The CB with RCD (Residual Current Device) is not suggested for the system.

2.6.4 Connecting Power Cables

The steps of connecting power cables are as follows:

1. Verify that all the switches of the UPS are completely open and the UPS internal maintenance bypass switch is open. Attach necessary warning signs to these switches to prevent unauthorized operation.
2. Open the back door of the cabinet, remove the plastic cover. The input and output terminal, battery terminal and protective earth terminal are shown in Fig.2-11 & Fig 2.13.

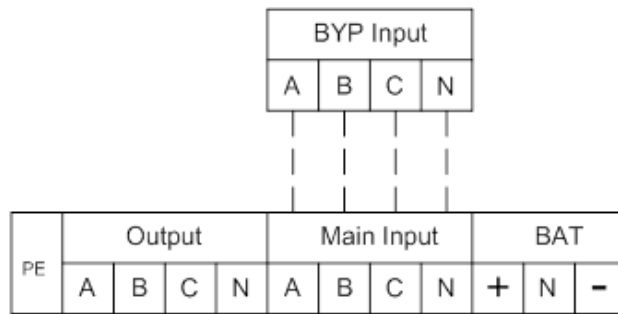

Fig.2-13 6-slot connections terminals

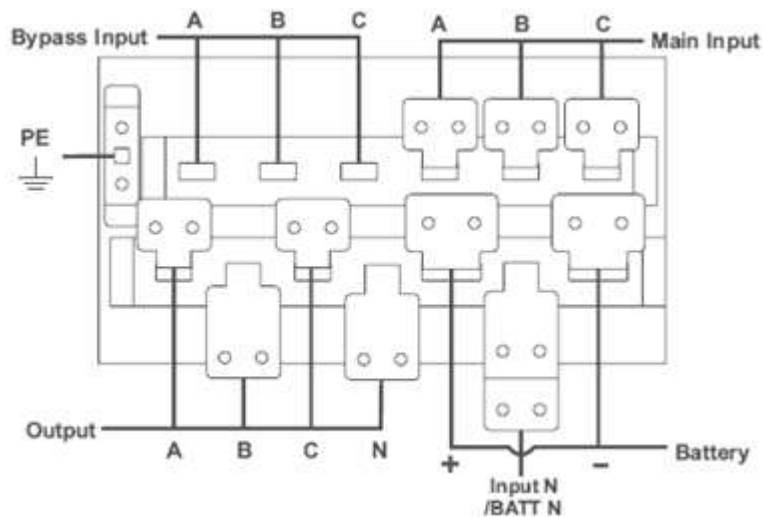

Fig.2-14 10-slot connections terminals

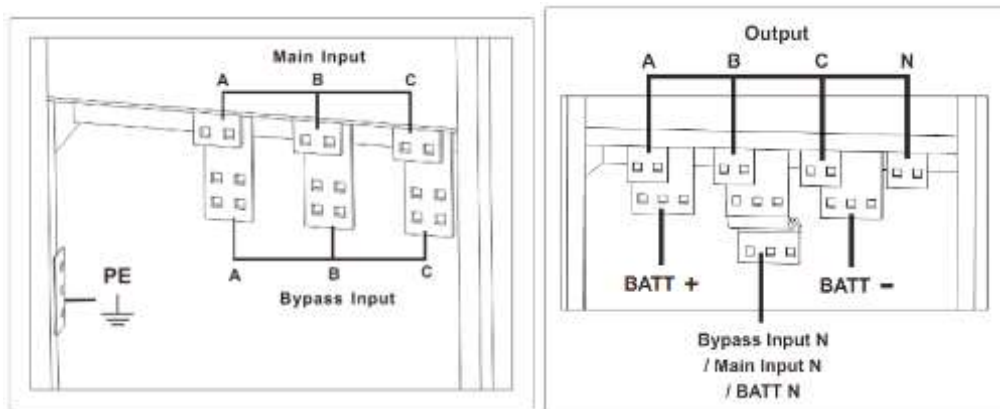

Fig.2-15 20-slot connections terminals

3. Connect the protective earth wire to protective earth terminal (PE).
4. Connect the AC input supply cables to the Input terminal and AC output supply cables to the Output terminal.
5. Connect the Battery cables to the Battery terminal.
6. Check to make sure there is no mistake and re-install all the protective covers.



Attention

The operations described in this section must be performed by authorized electricians or

qualified technical personnel. If you have any difficulties, contact the manufacturer or agency.



Warning

- Tighten the connections terminals to enough torque moment, refer to Table 3.3, and please ensure correct phase rotation.
- Before connection , ensure the input switch and the power supply are off , attach warnings label to warn not to operate by others
- The grounding cable and neutral cable must be connected in accordance with local and national codes.

2.7 Control and Communication Cables

The front panel of the bypass module provides dry contact interface (J2-J11) and communication interface (RS232, RS485,SNMP ,Intelligent card interface and USB port), as it is shown in Fig.2-14.

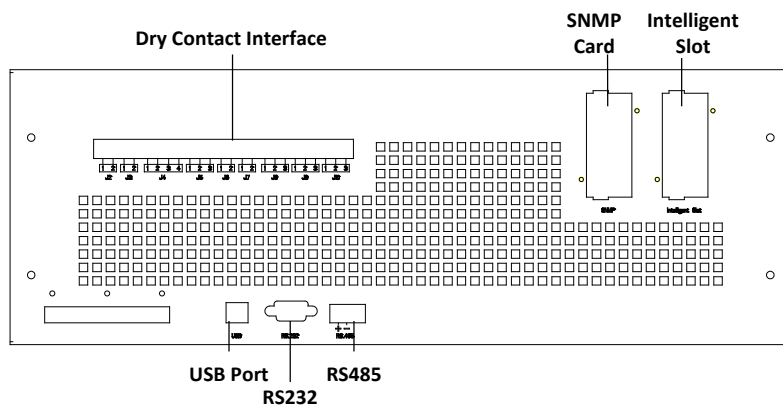

Fig.2-16 Dry contact & communication interface for 6-slot and 10-slot cabinet

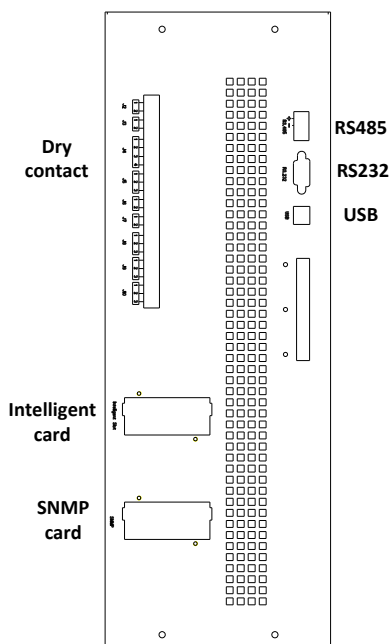

Fig.2-17 Dry contact & communication interface for 20-slot cabinet

The UPS accepts external signal from zero-voltage (dry) contacts connected through external dry contact terminals produced and phoenix terminals. Through software programming, these signals become active when these contacts connect to +24V to ground). The cables connected to DRY terminal must be separated from power cables. Moreover, these cables should be double insulated with a typical 0.5 to 1.5 mm² cross-section area for a maximum connection length between 25 and 50 meters.

2.7.1 Dry Contact Interface

Dry contact interface includes port J2-J11 and the functions of the dry contact are shown in Table 2.5.

Table 2.5 Functions of the port

Port	Name	Function
J2-1	TEMP_BAT	Detection of battery temperature
J2-2	TEMP_COM	Common terminal for temperature detection
J3-1	ENV_TEMP	Detection of environmental temperature
J3-2	TEMP_COM	Common terminal for temperature detection
J4-1	REMOTE_EPO_NC	Trigger EPO when disconnect with J4-2
J4-2	+24V_DRY	+24V
J4-3	+24V_DRY	+24V
J4-4	REMOTE_EPO_NO	Trigger EPO when shorted with J4-3
J5-1	+24V_DRY	+24V
J5-2	GEN_CONNECTED	Input dry contact , function is settable , Default: interface for generator
J5-3	GND_DRY	Ground for +24V
J6-1	BCB Drive	Output dry contact, function is settable. Default: Battery trip signal
J6-2	BCB_Status	Input dry contact, function is settable. Default: BCB Status and BCB Online, (Alert no battery when BCB Status is invalid).
J7-1	GND_DRY	Ground for +24V
J7-2	BCB_Online	Input dry contact, function is settable. Default: BCB Status and BCB Online (Alert no battery when BCB Status is invalid).
J8-1	BAT_LOW_ALARM_NC	Output dry contact (Normally closed), function is settable. Default: Low battery alarming
J8-2	BAT_LOW_ALARM_NO	Output dry contact (Normally open), function is settable. Default: Low battery alarming
J8-3	BAT_LOW_ALARM_GND	Common terminal for J8-1 and J8-2
J9-1	GENERAL_ALARM_NC	Output dry contact, (Normally closed) function is settable. Default: Fault alarming
J9-2	GENERAL_ALARM_NO	Output dry contact, (Normally open) function is settable. Default: Fault alarming
J9-3	GENERAL_ALARM_GND	Common terminal for J9-1 and J9-2
J10-1	UTILITY_FAIL_NC	Output dry contact, (Normally closed) function is settable.

		Default: Utility abnormal alarming
J10-2	UTILITY_FAIL_NO	Output dry contact, (Normally open) function is settable. Default: Utility abnormal alarming
J10-3	UTILITY_FAIL_GND	Common terminal for J10-1 and J10-2

Note

The settable functions for each port can be set by the monitor software.
The default functions of each port are described as follows.

Battery Warning Output Dry Contact Interface

The input dry contact J2 and J3 can detect the temperature of batteries and environment respectively, which can be used in environment monitoring and battery temperature compensation.

Interfaces diagram for J2 and J3 are shown in Fig.2-15, the description of interface is in Table 2.6.

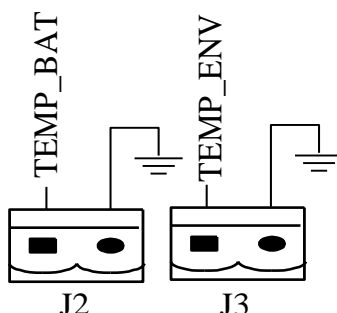

Fig.2-15 J2 and J3 for temperature detecting

Table 2.6 Description of J2 and J3

Port	Name	Function
J2-1	TEMP_BAT	Detection of battery temperature
J2-2	TEMP_COM	Common terminal
J3-1	ENV_TEMP	Detection of environmental temperature
J3-2	TEMP_COM	Common terminal

Note

Specified temperature sensor is required for temperature detection (R25=5Kohm, B25/50=3275), please confirm with the manufacturer, or contact the local maintenance engineers when placing an order.

Remote EPO Input Port

J4 is the input port for remote EPO. It requires shorting NC and +24V and disconnecting NO and +24V during normal operation, and the EPO is triggered when opening NC and +24V or shorting the NO and +24V. The port diagram is shown in Fig.2-16, and port description is shown in Table 2.7.

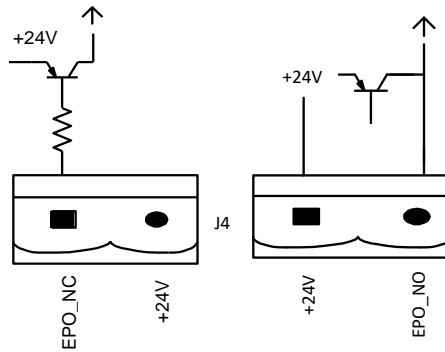

Fig.2-16 Diagram of input port for remote EPO

Table 2.7 Description of input port for remote EPO

Port	Name	Function
J4-1	REMOTE_EPO_NC	Trigger EPO when disconnect with J4-2
J4-2	+24V_DRY	+24V
J4-3	+24V_DRY	+24V
J4-4	REMOTE_EPO_NO	Trigger EPO when connect with J4-3

Generator Input Dry Contact

The default function of J5 is the interface for generator J5. Connect pin 2 of J5 with +24V power supply; it indicates that the generator has been connected with the system. The interface diagram is shown in Fig.2-17, and interface description is shown in Table 2.8.

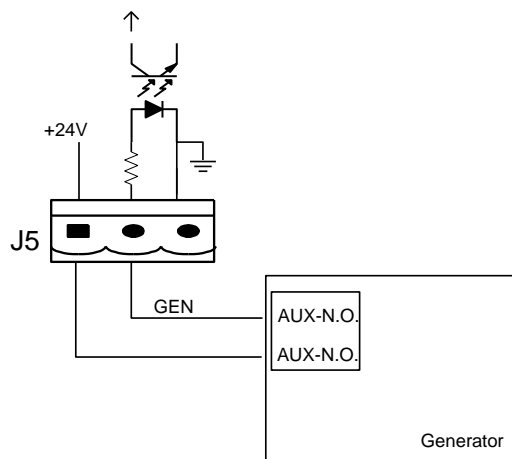

Fig.2-17 Diagram of status interface and connection of generator

Table 2.8 Description of status interface and connection of generator

Port	Name	Function
J5-1	+24V_DRY	+24V
J5-2	GEN_CONNECTED	Connection status of generator
J5-3	GND_DRY	Power ground for +24V

BCB Input Port

The default function of J6 and J7 are the ports of BCB. The port diagram is shown in Fig.2-18, and description is shown in Table 2.9.

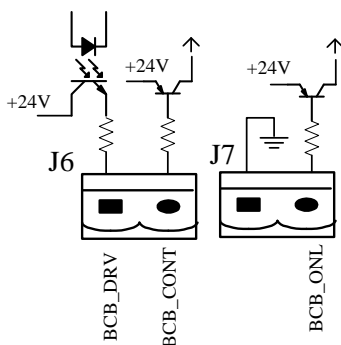

Fig.2-18 BCB Port

Table 2.9 Description of BCB port

Port	Name	Function
J6-1	BCB_DRIV	BCB contact drive, provides +24V voltage, 20mA drive signal
J6-2	BCB_Status	BCB contact status, connect with the normally open signal of BCB
J7-1	GND_DRY	Power ground for +24V
J7-2	BCB_Online	BCB on-line input (normally open) , BCB is on-line when the signal is connecting with J7-1

Battery Warning Output Dry Contact Interface

The default function of J8 is the output dry contact interface, which presents the battery warnings of low or excessive voltage, when the battery voltage is lower than set value, an auxiliary dry contact signal will be activated via the isolation of a relay. The interface diagram is shown in Fig.2-19, and description is shown in Table 2.10.

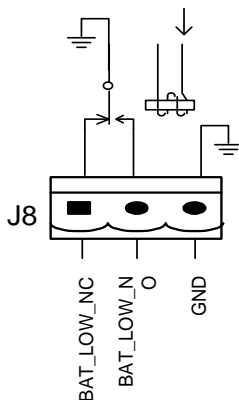

Fig.2-19 Battery warning dry contact interface diagram

Table2.10 Battery warning dry contact interface description

Port	Name	Function
J8-1	BAT_LOW_ALARM_NC	Battery warning relay (normally closed) will be open during warning
J8-2	BAT_LOW_ALARM_NO	Battery warning relay (normally open) will be closed during warning
J8-3	BAT_LOW_ALARM_GND	Common terminal

General Alarm Output Dry Contact Interface

The default function of J9 is the general alarm output dry contact interface. When one or more warnings are triggered, an auxiliary dry contact signal will be active via the isolation of a relay. The interface diagram is shown in Fig.2-20, and description is shown in Table 2.11.

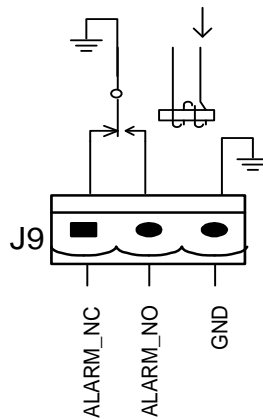

Fig.2-20 Integrated warning dry contact interface diagram

Table2.11 General alarm dry contact interface description

Port	Name	Function
J9-1	GENERAL_ALARM_NC	Integrated warning relay (normally closed) will be open during warning
J9-2	GENERAL_ALARM_NO	Integrated warning relay (normally open) will be closed during warning
J9-3	GENERAL_ALARM_GND	Common terminal

Utility Fail Warning Output Dry Contact Interface

The default function of J10 is the output dry contact interface for utility failure warning, when the utility fails, the system will send a utility failure warning information, and provide an auxiliary dry contact signal via the isolation of a relay. The interface diagram is shown in Fig.2-21, and description is shown in Table 2.12.

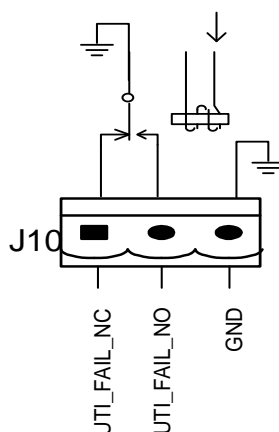

Fig.2-21 Utility failure warning dry contact interface diagram

Table 2.12 Utility failure warning dry contact interface description

Port	Name	Function
J10-1	UTILITY_FAIL_NC	Mains failure warning relay(normally closed) will be open during warning
J10-2	UTILITY_FAIL_NO	Mains failure warning relay (normally open) will be closed during warning
J10-3	UTILITY_FAIL_GND	Common terminal

2.7.2 Communication Interface

RS232、RS485 and USB port: Provide serial data which can be used for commissioning and maintenance by authorized engineers or can be used for networking or integrated monitoring system in the service room.

SNMP: Used on site installation for communication (Optional).

Intelligent card interface: Extension dry contact interface (Optional).

Chapter 3 LCD Panel

3.1 Introduction

This chapter introduces the functions and operator instructions of the operator control and display panel in detail, and provides LCD display information, including LCD display types, detailed menu information, prompt window information and UPS alarm information.

3.2 LCD panel for Power Module

The structure of LCD panels for power module is shown in Fig.3-1.

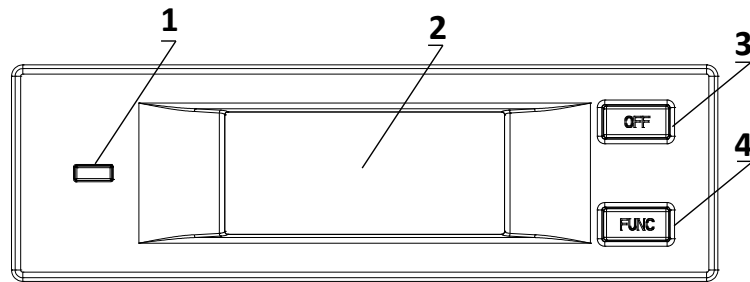

- 1: Status indicator 2: LCD Display
 3: OFF Key 4: FUNC Key

Fig.3-1 Control and display panel for power module

The operator control panel is divided into three functional areas : Status indicator , control and operation keys and LCD display.

3.2.1 LED Indicator

The LED indicator has green and red colors to indicate the statuses and faults by combinations of different colors and the time it lasts. The combinations are listed in Table 3.1



Table 3.1 Statuses and faults of different combinations

No.	LED combinations	Description
1	Green short-time flashing 1 (Green for 1S , Off for 2S)	Rectifier soft starting
2	Green short-time flashing 2 (Green for 2S , Off for 1S)	Inverter soft starting
3	Green medium-time flashing (Green for 1S , Off for 5S)	Power module inverter standby
4	Green long-time flashing (Green for 2S , Off for 10S)	Power module in deep sleep (shutdown)
5	Steady green	UPS is working normally
6	Red and Green Alternating (Red for 1S,Green for 5S)	The load powered by inverter with warnings (No battery , battery discharging, overload etc.)
7	Steady red	Power module shutdown by fault
8	Red medium-time flashing (Red for 1S , Off for 5S)	Shutdown manually or by <u>monitoring software</u>
9	Red short-time flashing (Red for 1S , Off for 1S)	Situation except above

3.2.2 Control and Operation Keys

The control and operation keys include FUNC keys and OFF key that have different functions:

- (a) The FUNC key is used for turning the display pages;
- (b) The OFF key is mainly for turning off the power module, as the following procedures:

- 1) Enable : LCD panel -> Menu Operate  -> Enable Module "OFF" Key 
- 2) Press the "OFF" key for 3 seconds , the power module will be excluded from the system. ;

(c) Pressing the "FUNC" keys resets the LCD display.

3.2.3 LCD Display

LCD is for displaying the information for the module and its structure is shown in Fig.4-2.

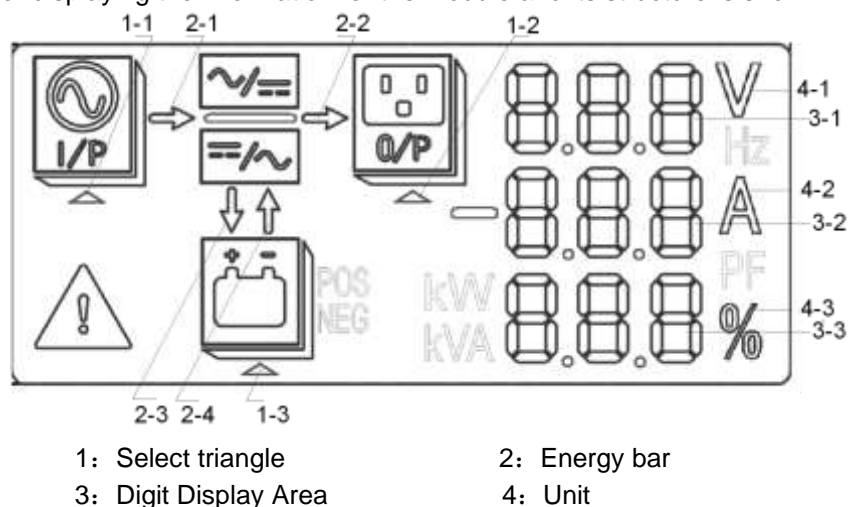







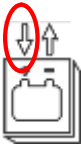



Fig.3-2 LCD display for Module

Users can browse the information of each power module by pressing the FUNC key to turn the pages.

- Select triangle of  highlighted :
Input information is presented in the Digit Displays Area : 3-phase voltage and 3-phase current.
- Select triangle of  highlighted :
Output information is presented in the Digit Displays Area : 3-phase voltage, 3-phase current and the 3-phase load percentage.
- Select triangle of  POS highlighted :
Battery information is presented in the Digit Displays Area : Battery positive voltage, battery positive charge/discharge current and bus positive voltage;
- Select triangle of  NEG highlighted:
Battery information is presented in the Digit Displays Area: battery negative voltage, battery negative charge/discharge current and bus negative voltage.

-  highlighted :
Fault and warning codes are shown in Digit Displays Area in recycle (shown with short dash when less than 3).The meanings of the codes are listed in Table 3.2.
-  flashing :
Indicating a fault occurs.
- Energy bar of  :
(a) Flashing: Rectifier soft start;
(b) Highlighted: The rectifier is working normally;
(c) Off: Other situation.
- Energy bar of  :
(a) Flashing: Inverter starting;
(b) Highlighted: Load on inverter;
(c) Off: Other situation.
- Energy bar of  :
(a) Flashing: low battery voltage ;
(b) Highlighted: Charging normally;
(c) Off: battery not connected.
- Energy bar of  :
(a) Lightened: Discharging mode;
(b) Off: battery not connected or charging.

Unit: Voltage (V), Current (A), Percentage (%).

When one power module is turning page, the other modules update within 2 seconds.

Table 3.2 codes for faults and warnings

Codes	Description	Codes	Description
16	Main voltage abnormal	67	Battery polarity reversed
18	Bypass phase sequence fault	69	Inverter protected
20	Bypass voltage abnormal	71	Neutral disconnected
28	Bypass Over-track frequency	74	Module shut down manual
30	Transfer times (from inverter to bypass) in 1 hour exceed the limit.	81	Battery or charger fail
32	Output shorted	83	Lost N+X redundancy
34	EOD of battery	85	EOD system inhibited
38	Battery test fail	93	Inverter IO CAN fail
41	Battery maintenance fail	95	Data CAN fail
47	Rectifier fail	97	Power share fail

49	Inverter fail	109	Inverter bridge open
51	Rectifier over temperature	111	Temperature difference over limit
53	Fan fail	113	Input current unbalanced
55	Output overload	115	DC bus over voltage
57	Output overload time out	117	Rectifier soft start fail
59	Inverter over temperature	119	Relay open
61	UPS inverter Inhibited	121	Relay shorted
65	Low battery	127	Transfer to inverter manually

3.3 UPS operator panel

The structure of operator control and display panel for cabinet is shown in Fig.3-3.

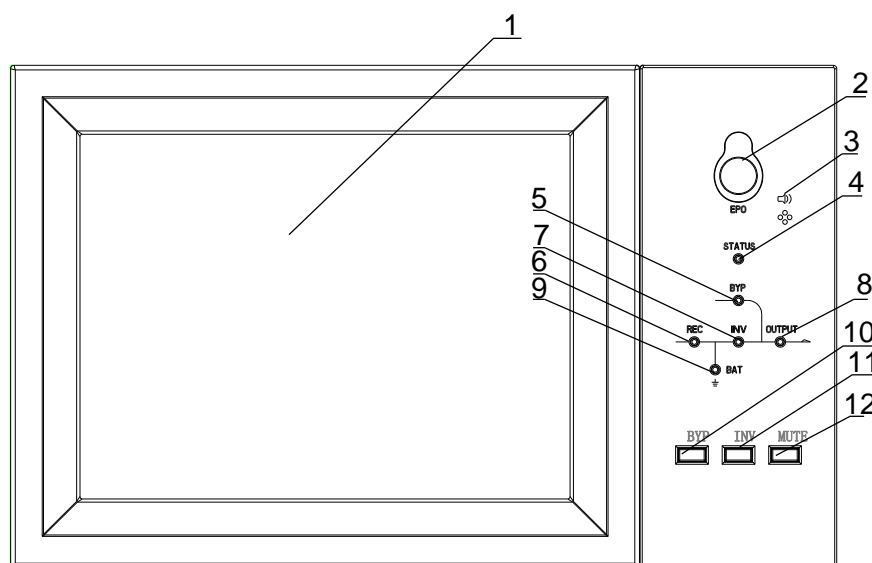

- | | | |
|-----------------------|-----------------------|---------------------------|
| 1: LCD touch screen | 2: EPO switch | 3: Audible Alarm (Buzzer) |
| 4: Status indicator | 5: Bypass indicator | 6: Rectifier indicator |
| 7: Inverter indicator | 8: Load indicator | 9: Battery indicator |
| 10: Bypass transfer | 11: Inverter transfer | 12: Mute |

Fig.3-3 Control and display panel for cabinet

The LCD panel for cabinet is divided into three functional areas : LED indicator , control and operation keys and LCD touch screen.

3.3.1 LED Indicator

There are 6 LEDs on the panel to indicate the operating status and fault. (See Fig. 3-3). The description of indicators is shown in Table 3.3

Table 3.3 Status description of indicator

Indicator	State	Description
Rectifier indicator	Steady green	Rectifier normal for all modules
	Flashing green	Rectifier normal for at least one module, mains normal
	Steady red	Rectifier fault
	Flashing red	Mains abnormal for at least one module
	Off	Rectifier not operating
	Steady green	Battery charging

Indicator	State	Description
Battery indicator	Flashing green	Battery discharging
	Steady red	Battery abnormal (battery failure, no battery or battery reversed) or battery converter abnormal (failure, over current or over temperature) , EOD
	Flashing red	Battery low voltage
	Off	Battery and battery converter normal, battery not charging
Bypass indicator	Steady green	Load supplied by bypass
	Steady red	Bypass abnormal or out of normal range, or static bypass switch fault
	Flashing red	Bypass voltage abnormal
	Off	Bypass normal
Inverter indicator	Steady green	Load supplied by inverter
	Flashing green	Inverter on, start, synchronization or standby (ECO mode) for at least one module
	Steady red	System output not supplied by inverter, inverter fault for at least one module.
	Flashing red	System output supplied by inverter, inverter fault for at least one module.
	Off	Inverter not operating for all modules
Load indicator	Steady green	UPS output ON and normal
	Steady red	UPS overload time is out, or output short, or output no power supply
	Flashing red	Overload output of UPS
	Off	No output of UPS
Status indicator	Steady green	Normal operation
	Steady red	Failure

There are two different types of audible alarm during UPS operation, as shown in Table 3.4.

Table 3.4 Description of audible alarm

Alarm	Description
Two short alarm with a long one	when system has general alarm (for example: AC fault),
Continuous alarm	When system has serious faults (for example: fuse blown or hardware failure)

3.3.2 Control and Operation Keys

Control and operation keys include four keys of 2, 10, 11 and 12(See Fig.3-3), which are used together with LCD touch screen. The functions description is shown in Table 3.5.

Table 3.5 Functions of Control and operation keys

Function Key	Description
EPO	Long press, cut off the load power (shut down the rectifier, inverter, static bypass and battery)
BYP	Long press, transfer to the bypass (Push the button up in the back of the door to enable , see Fig.5.2)
INV	Long press, transfer to the inverter
MUTE	Long press to switch between turning off and on the buzzing



Attention

When bypass frequency is over track, there is interruption time(less than 10ms) for transferring from bypass to inverter.

3.3.3 LCD touch Screen

Users can easily browse the information, operate the UPS, and set the parameters through the LCD touch screen, which is friendly for users.

After the monitoring system starts self-test, the system enters the home page, following the welcome window. The home page is shown in Fig.3-4.

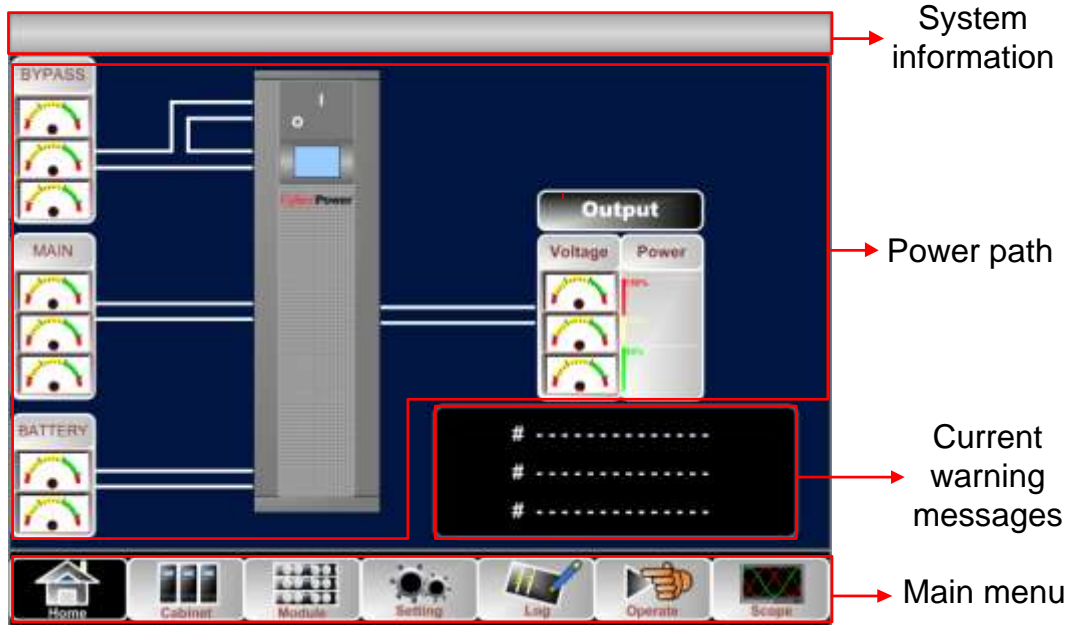

Fig.3-4 Home page

Home page consists of Status bar, Information display, warning information and main menu.

- **Status bar**
The Status bar contains the model of the product, capacity, operational mode , and the number of the power module and the time of the system.
- **Warning Information**
Display the warning information of the cabinet.
- **Information Display**
Users can check the information of the cabinet in this area.
The bypass voltage, main input voltage, battery voltage, and output voltages are presented in the form of gauge.
The loads are displayed in the form of bar chart in percentage. The green area stands for a load of less than 60%, yellow area for a load of 60%-100% and red area for a load of more than 100%.
The energy flow mimics the flow of the power.
- **Main Menu**
The main menu includes Cabinet, Module, Setting, log, Operate and Scope. Users can operate and control the UPS, and browse all measured parameters through main menu. The structure of the main menu tree is shown in Fig.3-5.

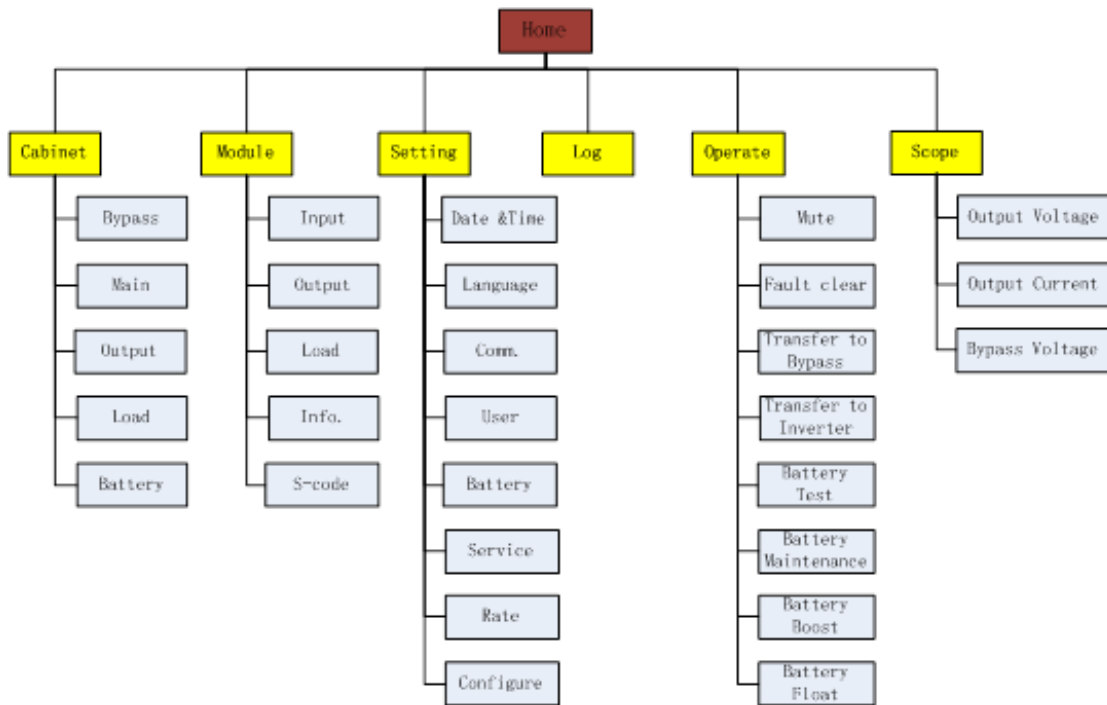



Fig.3-5 Structure of menu tree

3.4 Main Menu

The main menu includes Cabinet, Module, Setting, Log, Operate and Scope and it is described in details below.

3.4.1 Cabinet

Touch the icon , (At the bottom left of the screen), and the system enters the page of the Cabinet, as it is shown in Fig.3-6.

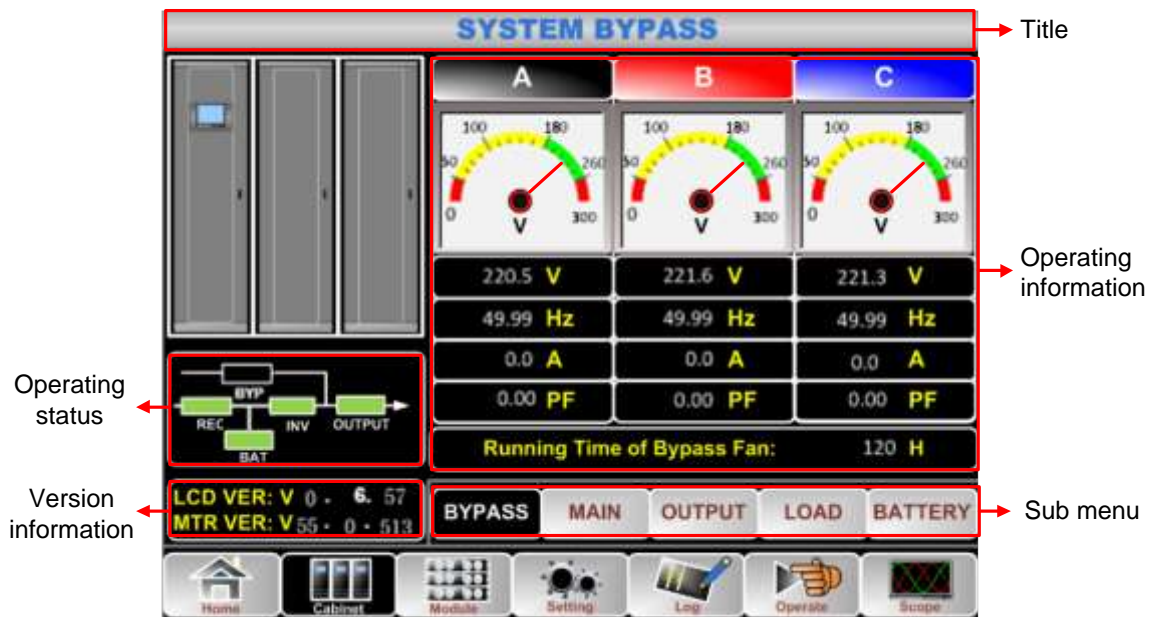

Fig.3-6 Cabinet

The Cabinet comprises sectors of title, information display, version running status, information display and submenu. The sectors are described as follows.

- Title
Display the information of the selected submenu.
- Running status
The squares shown on the mini current path represent the various UPS power paths and show the current UPS operating status. (The green square indicating the block working normally, the white indicating the absent of the block and red indicating the absence of the block or in fault).
- Version Information
The version information for LCD of the cabinet and monitor.
- Submenu
It includes the submenu of Bypass, Main, Output, load and battery.
- Information display
Display information of each submenu.
The interface of each submenu is shown in Fig.3-7.

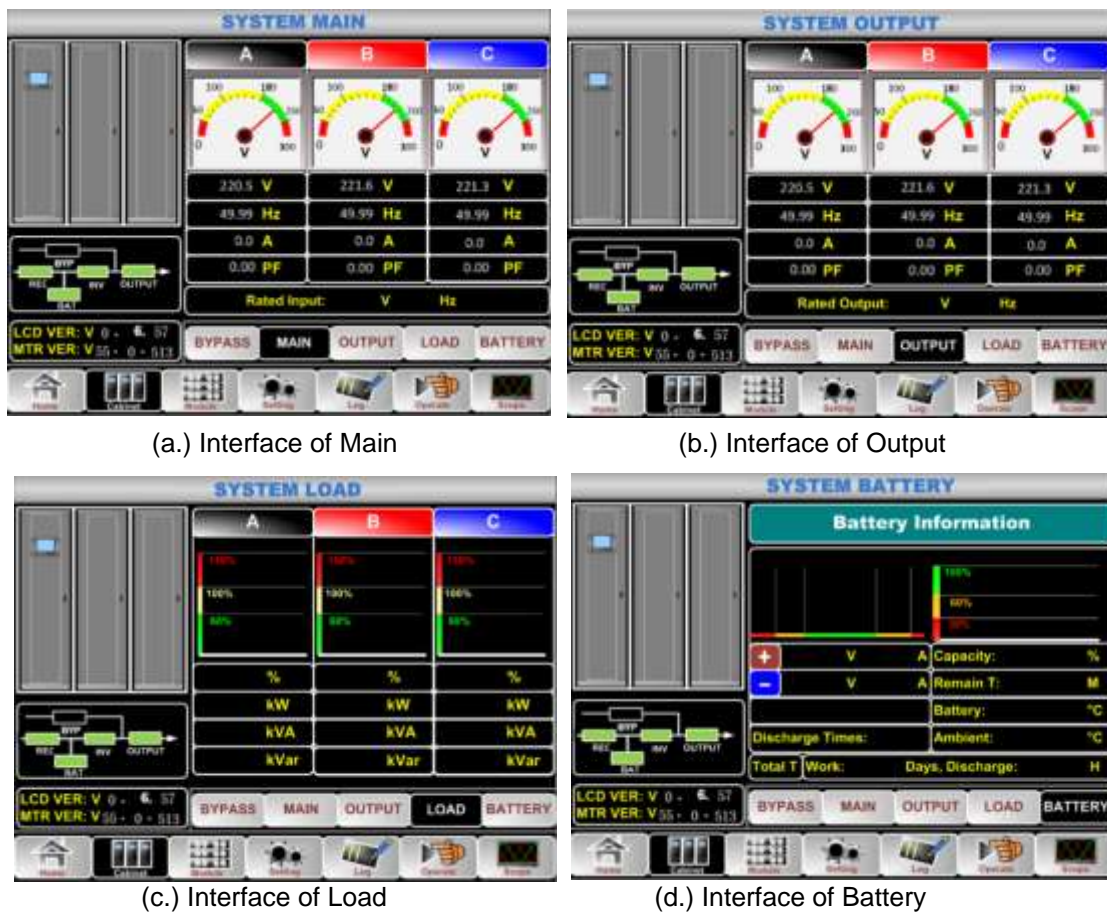

Fig.3-7 Submenu interface of Cabinet

The submenu of Cabinet is described in details below in Table 3.6.

Table 3.6 Description of each submenu of Cabinet

Submenu Name	Contents	Meaning
Main	V	Phase voltage
	Hz	Input frequency
	A	Phase current
	PF	Power factor

Submenu Name	Contents	Meaning
Bypass	V	Phase voltage
	Hz	Bypass frequency
	A	Phase current
	PF	Power factor
Output	V	Phase voltage
	Hz	Bypass frequency
	A	Phase current
	PF	Load power factor
Load	%	Load (The percentage of the UPS load)
	kW	Pout: Active power
	kVA	Sout: Apparent power
	kVar	Qout: Reactive power
Battery	V	Battery positive/negative voltage
	A	Battery positive/negative current
	Capacity (%)	The percentage compared with new battery capacity
	Remain T (Min)	Remaining battery backup time
	Battery(°C)	Battery Temp
	Ambient(°C)	Environmental Temp
	Total T Work (Days)	Total work time
	Total T Discharge (H)	Total discharging time

3.4.2 Module

Touch the icon , (At the bottom left of the screen), and the system enters the page of the Module, as is shown in Fig.3-8.

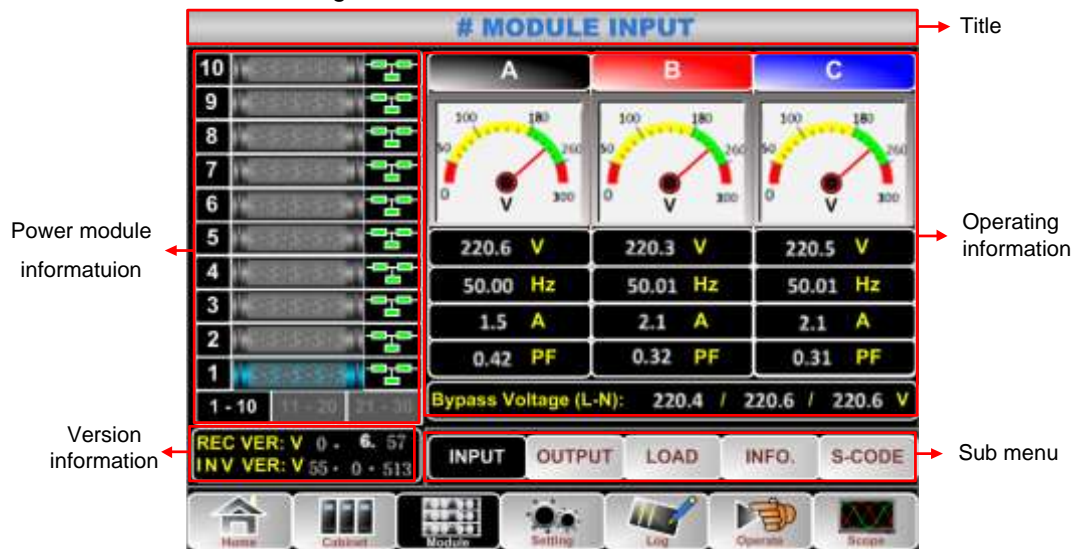

Fig.3.8 Module

The Module comprises sectors of title, information display, power module information, version information and submenu. The sectors are described as follows.

- Title
Present the title of submenu of the selected power module.
- Information display

- Display information of each submenu.
- Power module information
 - The users can choose the power module to browse the information in the “Information display” sector.
 - Colors of the square on the mimic current path represent the various power module paths and show the current operating status.
 - (a) The green square indicating the module working normally,
 - (b) The black indicating module in invalid
 - (c) The red indicating the absence of the module or in fault
- Take the 5#module  for example. It indicates that UPS is in Normal mode and the rectifier and inverter are working normally .The battery is not connected.
- Version Information
 - The version information for rectifier and inverter of the selected module.
- Submenu
 - The submenu includes Input, Output, Load, INFO and S-CODE.
 - Users can enter the interface of each submenu by directly touching the icon .Each interface of the submenu is shown in Fig.3-9.



Fig.3-9 Module menu

The submenus of Module are described below in details in Table 3.7.

Table 3.7 Description of each submenu of Module

Submenu Name	Contents	Meaning
Input	V	Input phase voltage of selected module
	Hz	Input frequency of selected module
	A	Input phase current of selected module
	PF	Input power factor of selected module
Output	V	Output phase voltage of selected module

Submenu Name	Contents	Meaning
	Hz	Output frequency of selected module
	A	Output phase current of selected module
	PF	Output load power factor of selected module
Load	%	Load (The percentage of the power module selected)
	KW	Pout: Active Power
	KVA	Sout: Apparent Power
	V	Load voltage of selected module
Information	BATT+(V)	Battery Voltage (positive)
	BATT-(V)	Battery Voltage (negative)
	BUS(V)	Bus Voltage(Positive & Negative)
	Charger(V)	Charger Voltage(Positive & Negative)
	Fan Time	Total Fan's Running time of the selected power module
	Inlet Temperature(°C)	Inlet Temperature of the selected power module
	Outlet Temperature(°C)	Outlet Temperature of the selected power module
S-code	Fault Code	For the maintenance personnel

3.4.3 Setting

Touch the icon , (At the bottom of the screen), and the system enters the page of the Setting, as it is shown in Fig.3-10.



Fig.3-10 Setting menu

The submenus are listed on the right side of the Setting page. Users can enter each of the setting interfaces by touching the relevant icon. The submenus are described in details below in Table 3.8.

Table 3.8 Description of each submenu of Setting

Submenu Name	Contents	Meaning
Date&Time	Date format setting	Three formats: (a) year/month/day, (b) month/date/year, (c) date/month/year

Submenu Name	Contents	Meaning
	Time setting	Setting time
Language	Current language	Language in use
	Language selection	Simplified Chinese and English selectable (The setting taking action immediately after touching the language icon)
COMM.	Device Address	Setting the communication address
	RS232 Protocol Selection	SNT Protocol, ModBus Protocol, YD/T Protocol and Dwin (For factory use)
	Baudrate	Setting the baudrate of SNT, ModBus and YD/T
	Modbus Mode	Setting mode for Modbus:ASCII and RTU selectable
	Modbus parity	Setting the parity for Modbus
USER	Output voltage Adjustment	Setting the Output Voltage
	Bypass Voltage Up Limited	Up limited working Voltage for Bypass, settable:+10%, +15%, +20%, +25%
	Bypass Voltage Down Limited	Down limited working Voltage for Bypass, settable:-10%, -15%, -20%, -30%, -40%
	Bypass Frequency Limited	Permitted working Frequency for Bypass Settable: +-1Hz, +-3Hz, +-5Hz
	Dust Filter Maintenance Period	Setting Dust Filter Maintenance Period
BATTERY	Battery Number	Setting the number of the battery (12V)
	Battery Capacity	Setting of the AH of the battery
	Float Charge Voltage/Cell	Setting the floating Voltage for battery cell (2V)
	Boost Charge Voltage/Cell	Setting the boost Voltage for battery cell (2V)
	EOD(End of discharge) Voltage/Cell,@0.6C Current	EOD voltage for cell battery,@0.6C current
	EOD(End of charge) Voltage/Cell,@0.15C Current	EOD voltage for cell battery,@0.15C current
	Charge Current Percent Limit	Charge current (percentage of the rated current)
	Battery Temperature Compensate	Coefficient for battery temperature compensation
	Boost Charge Time Limit	Setting boost charging time
	Auto Boost Period	Setting the auto boost period
	Auto Maintenance Discharge Period	Setting the period for auto maintenance discharge
SERVICE	System Mode	Setting the system mode: Single , parallel, Single ECO, parallel ECO,LBS, parallel LBS

Submenu Name	Contents	Meaning
RATE	Configure the rated Parameter	For the factory use
CONFIGURE	Configure the system	For the factory use

Note

- Users have various permissions to the configuration of the Setting :(a) for the Date &Time, LANGUAGE and COMM, user can set on their own without password. (b)For the USER, a one-level password is needed and the setting must be done by commissioning engineer (c) For the Battery and SERVICE, a Two-level password is needed and it is set by the after-service personal. (d)For the RATE and CONFIGURE, a Three-level password is needed and it is set only by the factory.
- The “C” stands for Ampere number. For instance, if the battery is 100AH, then C=100A.



Warning

Ensure the number of the battery, set via the menu or the monitoring software, is completely equal to the real installed number. Otherwise it will cause serious damage to the batteries or the equipment.

3.4.4 Log



Touch the icon , (At the bottom of the screen), and the system enters the interface of the Log, as it is shown in Fig.3-11.The log is listed in reverse chronological order(i.e. the first on the screen with #1 is the most new), which displays the events ,warnings and faults information and the data and time they occur and disappear.

NO.	M# EVENTS	TIME
1	0 # Load On UPS-Set	2014 - 2 - 14 16 :26 : 1
2	4 # Module Inserted-Set	2014 - 2 - 14 16 :24 : 27
3	0 # Byp Freq Over Track-Set	2014 - 2 - 14 16 :22 : 31
4	0 # Load On Bypass-Set	2014 - 2 - 14 16 :21 : 33
5	0 # Bypass Volt Abnormal-Set	2014 - 2 - 14 16 :21 : 33
6	0 # Load On Bypass-Set	2014 - 2 - 14 16 :19 : 41
7	0 # No Load-Set	2014 - 2 - 14 16 :18 : 45
8	4 # Load On Bypass-Set	2014 - 2 - 14 16 :18 : 45
9	0 # Byp Freq Over Track-Set	2014 - 2 - 14 16 :18 : 45
10	4 # Module-Exit-Set	2014 - 2 - 14 16 :26 : 1

Total Log Items 29

Home Cabinet Module Setting Log Operate Scope

Fig.3-11 Log menu

Every event recorded in the table includes the sequence number, the content of the event and the time stamp when it occurs, as is marked in the red box.

● Sequence number

The serial number for the event.

- **Content of the event**

Display the information of events, warnings and faults. (0# means the event happens to the cabinet, n# means the information is sent by the nth power module.)

- **Time for the Event**

The time the event occurs.

- **Total Log Items**

Display the total number of events. The system can record 895 events. If the number exceeds 895, the system will delete the earliest events.



Turn the list page up/down to check the information of the events.

The Table 3.9 below displays all the events and gives a brief explanation

Table 3.9 List for events

String Sequence	LCD Display	Explanation
1	Load On UPS-Set	Load On UPS
2	Load On Bypass-Set	Load On Bypass
3	No Load-Set	No Load (Output Power Lost)
4	Battery Boost-Set	Charger is Boosting Battery Voltage
5	Battery Float-Set	Charger is Floating Battery Voltage
6	Battery Discharge-Set	Battery is Discharging
7	Battery Connected-Set	Battery cables Connected
8	Battery Not Connected-Set	Battery cables Disconnected.
9	Maintenance CB Closed-Set	Maintenance CB is Closed
10	Maintenance CB Open-Set	Maintenance CB is Open
11	EPO-Set	Emergency Power Off
12	Module On Less-Set	Valid Inverter capacity is less than the load capacity
13	Module On Less-Clear	Event above disappears
14	Generator Input-Set	Generator as the Ac Input Source
15	Generator Input-Clear	Event above disappears
16	Utility Abnormal-Set	Utility (Grid) Abnormal
17	Utility Abnormal-Clear	Event above disappears
18	Bypass Sequence Error-Set	Bypass voltage Sequence is reverse
19	Bypass Sequence Error-Clear	Event above disappears
20	Bypass Volt Abnormal-Set	Bypass Voltage Abnormal
21	Bypass Volt Abnormal-Clear	Event above disappears
22	Bypass Module Fail-Set	Bypass Module Fail
23	Bypass Module Fail-Clear	Event above disappears
24	Bypass Overload-Set	Bypass Over load
25	Bypass Overload-Clear	Event above disappears
26	Bypass Overload Tout-Set	Bypass Over Load Timeout
27	Byp Overload Tout-Clear	Event above disappears
28	Byp Freq Over Track-Set	Bypass Frequency Over Track Range
29	Byp Freq Over Track-Clear	Event above disappears

30	Exceed Tx Times Lmt-Set	Transfer times (from inverter to bypass) in 1 hour exceed the limit.
31	Exceed Tx Times Lmt-Clear	Event above disappears
32	Output Short Circuit-Set	Output shorted Circuit
33	Output Short Circuit-Clear	Event above disappears
34	Battery EOD-Set	Battery End Of Discharge
35	Battery EOD-Clear	Event above disappears
36	Battery Test-Set	Battery Test Starts
37	Battery Test OK-Set	Battery Test OK
38	Battery Test Fail-Set	Battery Test fails
39	Battery Maintenance-Set	Battery Maintenance Starts
40	Batt Maintenance OK-Set	Battery maintenance succeeds
41	Batt Maintenance Fail-Set	Battery maintenance fails
42	Module Inserted-Set	N# Power Module joins the system
43	Module Exit-Set	N# Power Module quits the system.
44	Rectifier Fail-Set	N# Power Module Rectifier Fails
45	Rectifier Fail-Clear	Event above disappears
46	Inverter Fail-Set	N# Power Module Inverter Fail
47	Inverter Fail-Clear	Event above disappears
48	Rectifier Over Temp.-Set	N# Power Module Rectifier Over Temperature
49	Rectifier Over Temp.-Clear	Event above disappears
50	Fan Fail-Set	N# Power Module Fan Fail
51	Fan Fail-Clear	Event above disappears
52	Output Overload-Set	N# Power Module Output Over Load
53	Output Overload-Clear	Event above disappears
54	Inverter Overload Tout-Set	N# Power Module Inverter Over Load Timeout
55	INV Overload Tout-Clear	Event above disappears
56	Inverter Over Temp.-Set	N# Power Module Inverter Over Temperature
57	Inverter Over Temp.-Clear	Event above disappears
58	On UPS Inhibited-Set	Inhibit system transfer from bypass to UPS (inverter)
59	On UPS Inhibited-Clear	Event above disappears
60	Manual Transfer Byp-Set	Transfer to bypass manually
61	Manual Transfer Byp-Set	Cancel to bypass manually
62	Esc Manual Bypass-Set	Escape transfer to bypass manually command
63	Battery Volt Low-Set	Battery Voltage Low
64	Battery Volt Low-Clear	Event above disappears
65	Battery Reverse-Set	Battery pole (positive and negative) are reverse
66	Battery Reverse-Clear	Event above disappears
67	Inverter Protect-Set	N# Power Module Inverter Protect (Inverter Voltage Abnormal or Power Back feed to DC Bus)
68	Inverter Protect-Clear	Event above disappears
69	Input Neutral Lost-Set	Input Grid Neutral Lost

70	Bypass Fan Fail-Set	Bypass Module Fan Fail
71	Bypass Fan Fail-Clear	Event above disappears
72	Manual Shutdown-Set	N# Power Module Manually Shutdown
73	Manual Boost Charge-Set	Manually Battery Boost Charge
74	Manual Float Charge-Set	Manually Battery Float Charge
75	UPS Locked-Set	Inhibit to shut down the UPS
76	Parallel Cable Error-Set	Parallel cable in error
77	Parallel Cable Error-Clear	Event above disappears
78	Lost N+X Redundant	Lost N+X Redundant
79	N+X Redundant Lost-Clear	Event above disappears
80	EOD Sys Inhibited	System is inhibited to supply after the battery is EOD (end of discharging)
81	Power Share Fail-Set	Power share is not in balance
82	Power Share Fail-Clear	Event above disappears
83	Input Volt Detect Fail-Set	Input Voltage is abnormal
84	Input Volt Detect Fail-Clear	Event above disappears
85	Battery Volt Detect Fail-Set	Battery Voltage is abnormal
86	Batt Volt Detect Fail-Clear	Event above disappears
87	Output Volt Fail-Set	Output Voltage is abnormal
88	Output Volt Fail-Clear	Event above disappears
89	Outlet Temp. Error-Set	Outlet Temperature is abnormal
90	Outlet Temp. Error-Clear	Event above disappears
91	Input Curr Unbalance-Set	Input current is not balance
92	Input Curr Unbalance-Clear	Event above disappears
93	DC Bus Over Volt-Set	DC bus over Voltage
94	DC Bus Over Volt-Clear	Event above disappears
95	REC Soft Start Fail-Set	Rectifier soft start fails
96	REC Soft Start Fail-Clear	Event above disappears
97	Relay Connect Fail-Set	Relay in open circuit
98	Relay Connect Fail-Clear	Event above disappears
99	Relay Short Circuit-Set	Relay shorted
100	Relay Short Circuit-Clear	Event above disappears
101	No Inlet Temp. Sensor-Set	The inlet temperature sensor is not connected or abnormal
102	No Inlet Temp Sensor-Clear	Event above disappears
103	No Outlet Temp. Sensor-Set	The Outlet temperature sensor is not connected or abnormal
104	No Outlet TmpSensor-Clear	Event above disappears
105	Inlet Over Temp.-Set	Inlet over temperature
106	Inlet Over Temp.-Clear	Event above disappears



Note

Different colors of the words represent different level of events:

- (a) Green, an event occurs ;
- (b) Grey, the event occurs then clears ;
- (c) Yellow, warning occurs ;
- (d) Red, faults happen.

3.4.5 Operate

Touch the icon  (At the bottom of the screen), and the system enters the page of the “Operate”, as it is shown in Fig.3-12.

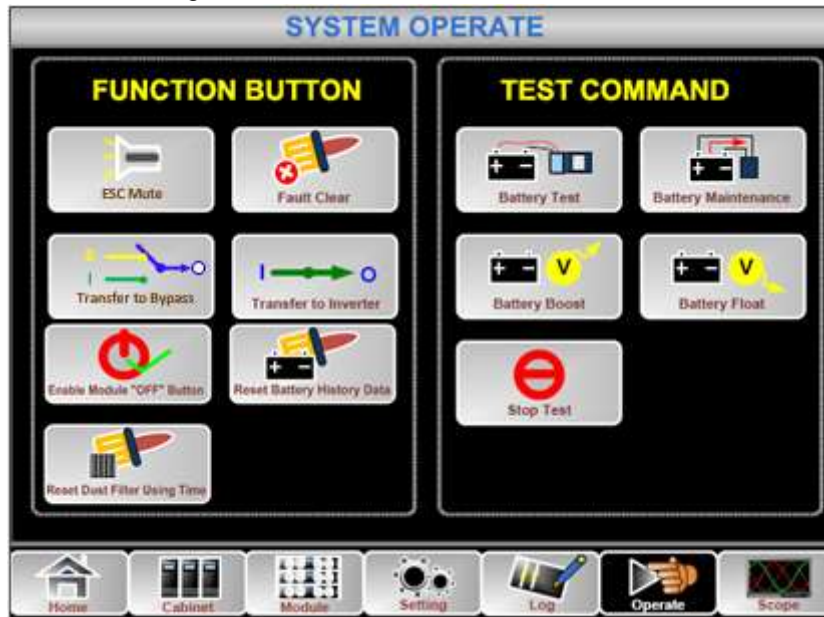



Fig.3-12 Operate menu

The “Operate” menu includes FUNCTION BUTTON and TEST COMMAND. The contents are described in details below.

FUNTION BUTTON

● Clear/Restore Buzzing

Mute or Restore buzzing of the system by touching the icon  or .

● Fault Clear

Clear the faults by touching the icon .

● Transfer to and ESC Bypass

Transfer to bypass mode or cancel this command by touching the icon  or .

● Transfer to Inverter

Transfer the bypass mode to Inverter Mode by touching the icon .

● Enable Module “OFF” Button

Enable the switch for powering off the Power Module by touching the icon .

- **Reset Battery History Data**

Reset the battery history data by touching the icon  , the history data includes the times of discharge, days for running and hours of discharging.

- **Reset Dust filter Using Time**

Reset the time of dust filter using by touching the icon  , it includes the days of using and maintenance period.

TEST COMMAND

- **Battery Test**

By touching the icon  , the system transfer to the Battery mode to test the condition of the battery. Ensure the bypass is working normally and the capacity of the battery is no less than 25%.

- **Battery Maintenance**

By touching the icon  , the system transfers to the Battery mode. This function is used for maintaining the battery, which requires the normality of the bypass and minimum capacity of 25% for the battery.

- **Battery Boost**

By touching the icon  , the system starts boost charging.

- **Battery Float**

By touching the icon  , the system starts float charging.

- **Stop Test**

By touching the icon  , the system stops battery test or battery maintenance.

3.4.6 Scope

Touch the icon  , (At the bottom right of the screen), and the system enters the page of the Scope, as it is shown in Fig.3-13.

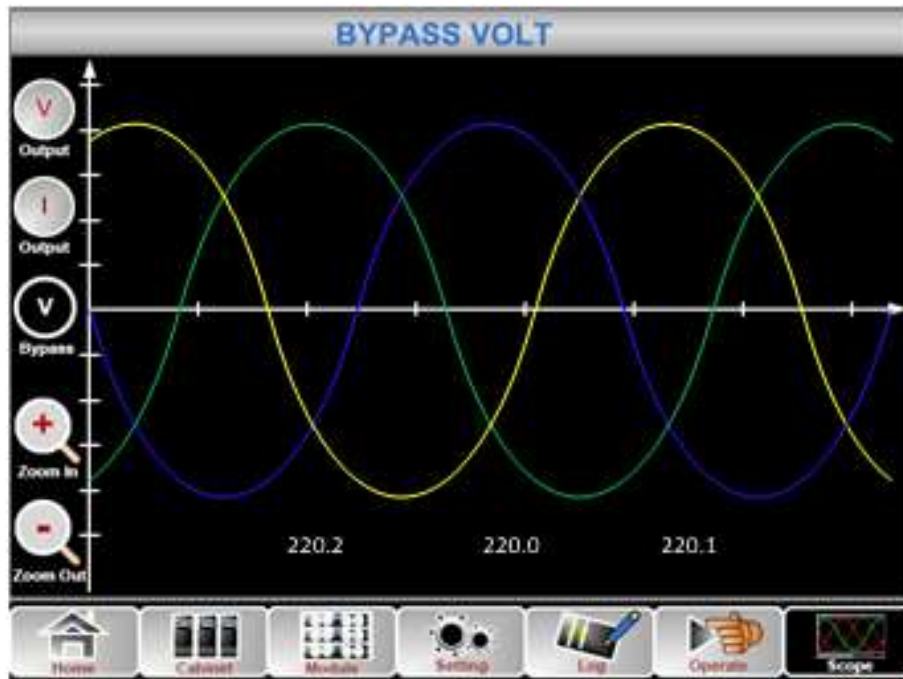







Fig.3-13 Scope Menu

Users can view the waves for output voltage, output current and bypass voltage by touching the corresponding icon in the left side of the interface. The waves can be zoomed in and zoom out.

-  Touch the icon to display the 3 phase output voltage.
-  Touch the icon to display the 3 phase output current.
-  Touch the icon to display the 3 phase bypass voltage.
-  Touch the icon to zoom in the wave.
-  Touch the icon to zoom out wave.

Chapter 4 Operations

4.1 UPS Start-up

4.1.1 Start in Normal Mode

The UPS must be started up by commissioning engineer after the completeness of installation. The steps below must be followed :

1. Ensure all the external circuit breakers are open.
2. Close the input external circuit breakers and the system starts initializing. If the system has dual inputs close both of the breakers.
3. The LCD in front of the cabinet is lit up. The system enters the home page, as shown in Fig.4-4.
4. Notice the energy bar in the home page, and pay attention to the LED indicators. The rectifier flashes indicating the rectifier is starting up. The LED indicators are listed below in Table 4.1.

Table 4.1 Rectifier starting up

Indicator	Status	Indicator	Status
Rectifier	green flashing	Inverter	off
Battery	red	Load	off
Bypass	off	Status	red

5. After 30S, the rectifier indicator goes steady green, presenting the finishing of rectification and bypass static switch closes then the inverter is starting up. The LED indicators are listed below in Table.4.2.

Table 4.2 Inverter starting up

Indicator	Status	Indicator	Status
Rectifier	green	Inverter	green flashing
Battery	red	Load	green
Bypass	green	Status	red

6. The UPS transfers from the bypass to inverter after the inverter goes normal. The LED indicators are listed below in Table 4.3.

Table 4.3 Supplying the load

Indicator	Status	Indicator	Status
Rectifier	green	Inverter	green
Battery	red	Load	green
Bypass	off	Status	red

7. The UPS is in Normal Mode. Close the battery circuit breakers and the UPS starts charging the battery. The LED indicators are listed below in Table 4.4.

Table 4.4 Normal mode

Indicator	Status	Indicator	Status
Rectifier	green	Inverter	green
Battery	green	Load	green
Bypass	off	Status	green

8. Close the output circuit breaker for the load and it finishes the starting up for the UPS.



Note

- When the system starts, the stored setting will be loaded.
- Users can browse all events during the process of the starting up by checking the

menu Log.

- Users can check the information of the power module by the keys in the front of it.

4.1.2 Start from Battery

The start from battery is referring to battery cold start. Take the 10-slot UPS as example, the steps for the start-up are as follows :

1. Confirm the battery is correctly connected; close the external battery circuit breakers.
2. Press the red button for the battery cold start (See Fig.4-1). The system is then powered by the battery. For the 20-slot UPS, there are 2 battery cold start button, for each of the button, it can only start the power modules of its cabinet(See Fig.4-2).

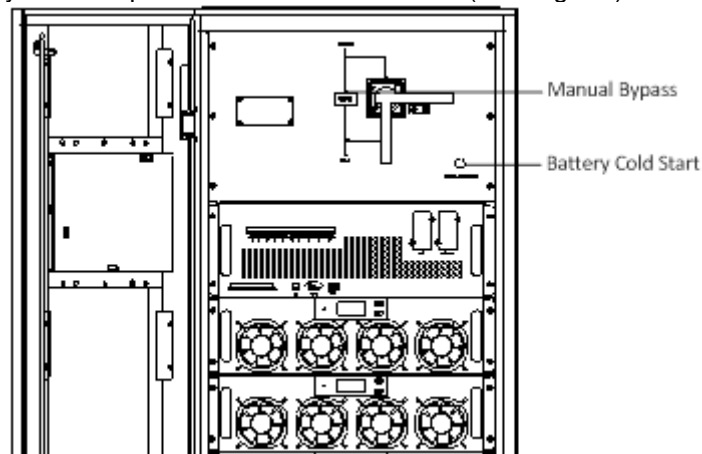

Fig.4-1The position of the battery cold start button for 10-slot cabinet

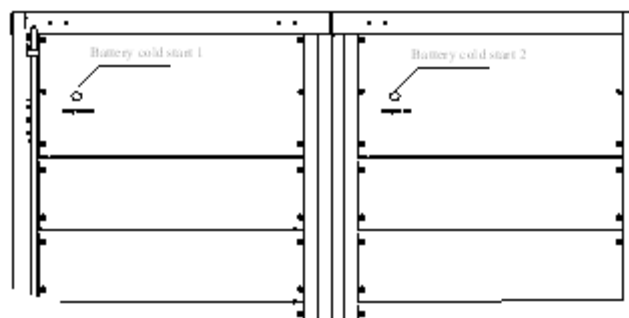

Fig.4-2 the position of the battery cold start button for 20-slot cabinet

3. After that, the system is starting up following steps 3 in section 5.1.1 and the system transfers to battery mode in 30S.
4. Close the external output power supply isolation to supply the load, and the system is working on battery mode.

4.2 Procedure for Switching between Operation Modes

4.2.1 Switching the UPS from Normal Mode into Battery Mode

The UPS transfers to Battery model immediately after the utility (mains voltage) is failed or drops down below the predefined limit.

4.2.2 Switching the UPS from Normal Mode into Bypass Mode

Two ways to transfer the UPS into Bypass mode from Normal mode:

- (a) Enter the menu Operate, touch the icon “transfer to bypass”  and the system transfers to bypass mode ;

- (b) Press and hold the BYP key on the operator control panel for longer than two seconds and the system transfers to bypass mode. This needs to enable the switch behind the front door. See Fig.4-3.

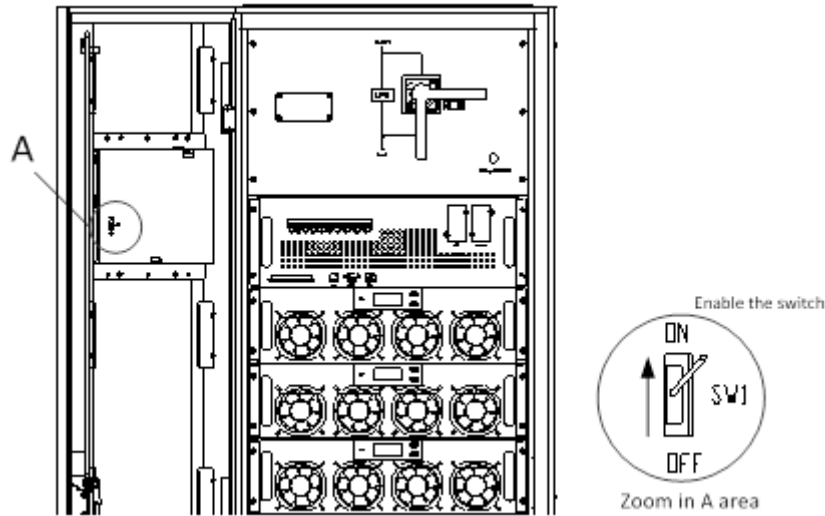

Fig.4-3 Enable the switch



Warning

Ensure the bypass is working normally before transferring to bypass mode. Or it may cause failure.

4.2.3 Switching the UPS into Normal Mode from Bypass Mode

Two ways to transfer the UPS into Normal mode from Bypass Mode:

- (a) Enter the menu Operate, touch the icon transfer to inverter  and the system transfers to bypass mode
 (b) Press and hold the INV key on the operator control panel for longer than two seconds and the system transfers to Normal mode.

 **Note**

Normally, the system will transfer to the Normal mode automatically. This function is used when the frequency of the bypass is over track and when the system needs to transfer to Normal mode by manual.

4.2.4 Switching the UPS from Normal Mode into Maintenance Bypass Mode

These following procedures can transfer the load from the UPS inverter output to the maintenance bypass supply, which is used for maintaining the bypass module (for 6-slot and 10-slot cabinet) and monitoring, static bypass unit (for 20-slot cabinet).

1. Transfer the UPS into Bypass mode following section 4.2.2.
2. Open the battery breaker and close the maintenance bypass. And the load is powered through maintenance bypass and static bypass.
3. Pull out the bypass module (for 6-slot and 10-slot cabinet) , and dismantle monitoring, static bypass unit (for 20-slot cabinet) and the load is powered through maintenance bypass.

**Warning**

Before making this operation, read messages on LCD display to be sure that bypass supply is regular and the inverter is synchronous with it, so as not to risk a short interruption in powering the load.

**Danger**

If you need to maintain the power module, wait for 10 minutes to let the DC bus capacitor fully discharge before removing the cover.

4.2.5 Switching the UPS into Normal Mode from Maintenance Bypass Mode

These following procedures can transfer the load from the Maintenance Bypass mode to inverter output.

1. The bypass turns on 30S after the LED touch screen goes on, the bypass indicator goes green and the load is powered through maintenance bypass and static bypass.
2. Turn off the maintenance bypass switch and the load is powered through bypass. The rectifier starts followed by the inverter.
3. After 60S, the system transfers to Normal mode.

4.3 Battery Maintenance

If the battery is not in use for a long time, it is necessary to test the condition of the battery. Two methods are provided:



1. Manual Discharging test. Enter the menu Operate, as is shown in Fig.5-4 and touch the icon “Battery maintenance”  , the system transfers into the Battery mode for discharging. The system will stop discharging when the battery will have 20% of capacity or in low voltage. Users can stop the discharging by touching the “Stop Test” icon .



Fig.4-4 Battery maintenance

2. Auto discharging. The system can maintenance the battery automatically when the setting is done. The setting procedures are as follows.
 - (a) Enable battery auto discharge. Enter the “CONFIGURE” page of the menu Setting, tick the “Battery Auto Discharge” and confirm (This needs to be done by factory).
 - (b) Setting period for battery auto discharge. Enter the “BATTERY” page of the Setting (See Fig.5-5), Set the period time in the item “Auto Maintenance Discharge Period” and confirm.



Fig.4-5 Setting period for battery auto discharge



Warning

The load for the auto maintenance discharge should be 20%-100% , if not, the system will not start the process automatically.

4.4 EPO

The EPO button located in the operator control and display panel (with cover to avoid disoperation, see Fig.5-6) is designed to switch off the UPS in emergency conditions (e.g., fire, flood, etc.). To achieve this, just press the EPO button, and the system will turn off the rectifier, inverter and stop powering the load immediately (including the inverter and bypass), and the battery stops charging or discharging.

If the input utility is present, the UPS control circuit will remain active; however, the output will be turned off. To completely isolate the UPS, users need to open the external mains input supply to the UPS. Users can restart the UPS by powering the UPS again.



Warning

When the EPO is triggered, the load is not powered by the UPS. Be careful to use the EPO function.

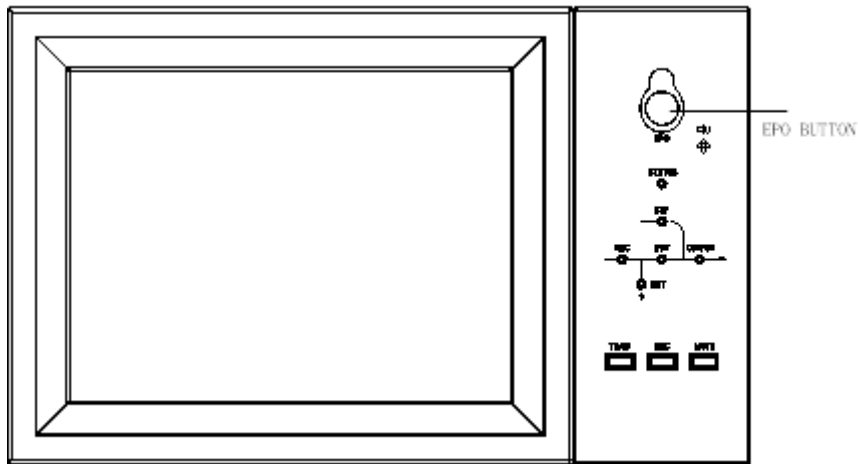

Fig .4-6 EPO Button

4.5 Installation of Parallel Operation System

For the 6-slot and 10-slot system ,it can have three UPS cabinets in parallel, which can extend to a capacity of total 900KVA.However, for the 20-slot system, parallel is not supported at present.

Two UPS cabinets are connected as is shown in Fig.4-6.

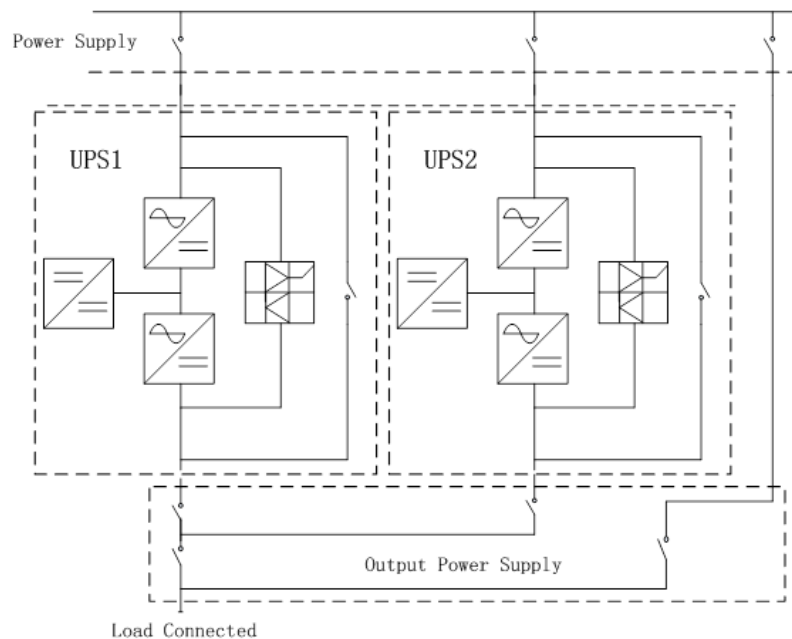

Fig. 4-6 Parallel diagram

The parallel board is located at the back of the UPS cabinet, whose name is PS1203-TF4 as is shown in Fig.4-7.

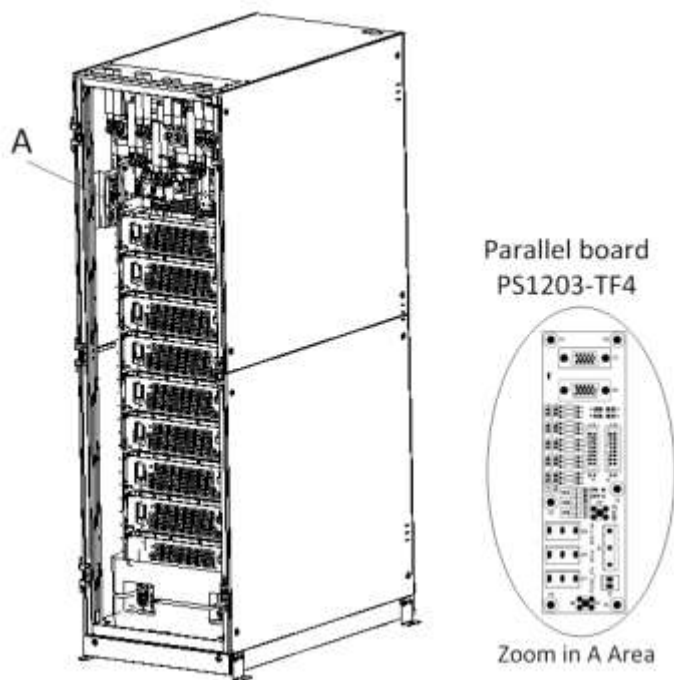

Fig.4-7 Location of the Parallel board

The control cables for the parallel operation must be connected with all single devices to form a closed loop, as is shown in Fig.4-8.

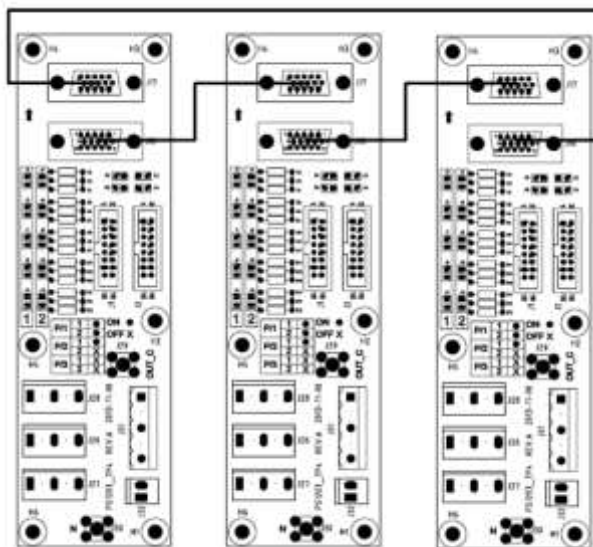

Fig.4-8 Parallel connection

For more details of parallel operation, please refer to the “Instruction for Parallel Operation of Modular UPS”.

Chapter 5 Maintenance



This chapter introduces UPS maintenance, including the maintenance instructions of power module and monitoring bypass module and the replacement method of dust filter.

5.1 Precautions

1. Only certified engineers are authorized to maintain the UPS.
2. The components or PCBs should be disassembled from top to bottom, so as to prevent any inclination from high gravity center of the cabinet.
3. To ensure the safety before maintaining, measure the voltage between operating parts and the earth with multi-meter to ensure the voltage is lower than hazardous voltage, i.e. DC voltage is lower than 60Vdc, and AC maximum voltage is lower than 42.4Vac.
4. Wait 10 minutes before opening the cover of the power module or the bypass after pulling out from the Cabinet.

5.2 Instruction for Maintaining Power Module

Confirm the UPS is operating in Normal Mode and the bypass is working normally before pulling out the power module needed to be repaired.

1. Ensure the remaining power module will not be overloaded.
2. Power off the module. 1) Enable LCD panel -> Menu Operate  -> Enable Module "OFF" Key  ; 2) Press the "OFF" key for 3 seconds, the power module quits from the system.
3. Remove the mounting screw on the two front sides of the power module (See Fig.3-10) and pull out the module by two persons.
4. Wait 10 mins before opening the cover for repairing.
5. After the repairing is done, push the power module into the cabinet following the steps in section 3.3.2 and the power module will automatically join the system.

5.3 Instruction for Maintaining

5.3.1 Maintaining Bypass Module for 6-slot and 10-slot Cabinet

Confirm the UPS is operating in Normal mode and the bypass is working normally before pulling out the bypassing module needed to be repaired. Follow the steps below to maintain the bypass module.

1. Transfer the system to bypass mode through the LCD control panel (Refer to section 4.5.5)
2. Open the battery switch, close maintenance bypass switch; the UPS power will be supplied by maintenance bypass.
3. Pull out the bypass module and the load is powered through maintenance bypass.
4. Remove the mounting screw on the two front sides of the bypass module (See Fig.3-10) and the front signal cable connects to the bypass module.
5. Pull out the bypass module and the LCD touch screen goes off.
6. Wait 10 mins before opening the cover for repairing.
7. After the repairing is done, push the bypass module into the cabinet following the steps in section 3.3.2 and the LED touch screen goes on.
8. The bypass turns on 30S after the LED touch screen goes on and the bypass indicator goes green and the load is powered through maintenance bypass and static bypass.
9. Turn off the maintenance bypass switch and the load is powered through bypass. The rectifier starts followed by the inverter.
10. After 60S, the system transfers to Normal mode.

5.3.2 Maintaining Static Bypass Unit for 20-slot Cabinet

1. Transfer the system to bypass mode through the LCD control panel (Refer to section 4.5.5);
2. Open the battery switch, Close maintenance bypass switch; the UPS power will be supplied by maintenance bypass;
3. Open the Main Input switch, Input Bypass switch and UPS output switch;
4. Disconnect Inner Control Neutral cable as Fig.6-1;
5. Take out the screws fixed on the fan panel and dismantle the fan panel;
6. Take out the two sets of control signal cables (in DB9 type);
7. Take out the fan units and remove the cables for the fans;
8. Dismantle the screws that fix the static bypass unit and copper bars;
9. Pull the static bypass unit to an extent which can make the maintenance possible (the static bypass unit can be repaired without taking out);
10. After the maintenance is done, push the static bypass inside;
11. Fix the static bypass and inner copper bars from the back of the cabinet;
12. Connect the cables for the fans and restore the fan units;
13. Connect two sets of control signal cables (in DB9 type);
14. Install the fan panel, fix the screws;
15. Close the UPS bypass input switch, output switch, main input switch in order;
16. Connect Inner Control Neutral cable as Fig.6-1
17. 2 minutes after the power on, there is energy flow in the LCD panel showing that the load is supplied by static bypass and manual bypass
18. Open the manual bypass switch, the Inverter will start automatically. After 60s, the UPS will run in Normal mode, which indicates the maintenance is done successfully.

Note: If it needs to take out the static bypass unit to do the repair, a forklift is suggested. (The weight of the static bypass unit can be 55kg).

5.3.3 Maintenance for the Air-drawing fans

1. Take out the fan unit panel
2. Push the button of the fans to turn off the fans
3. Change the fans
4. Push the button to turn on the fans again
5. Install the fan panel

5.3.4 Battery Maintenance

For the Lead-Acid maintenance free battery, when maintenance the battery according to requirements, battery life can be prolonged. The battery life is mainly determined by the following factors:

1. Installation. The battery should be placed in dry and cool place with good ventilation. Avoid direct sunlight and keep away from heat source. When installing, ensure the correct connection to the batteries with same specification.
2. Temperature. The most suitable storage temperature is 20 °C to 25°C.
3. Charging/discharging current. The best charging current for the lead-acid battery is 0.1C. The maximum current for the battery can not 0.3C. The suggested current is 0.05C-3C.
4. Charging voltage. In most of the time, the battery is in standby state. When the utility is normal, the system will charge the battery in boost mode (Constant voltage with maximum limited) to full and then transfers to the state of float charge.
5. Discharge depth. Avoid deep discharging, which will greatly reduce the life time of the battery. When the UPS runs in battery mode with light load or no load for a long time, it will cause the battery to deep discharge.
6. Check periodically. Observe if any abnormality of the battery, measure if the voltage of each battery are in balance. Discharge the battery periodically.

5.3.5 Disconnect the Inner Control Neutral cable

Inner control Neutral cable can be disconnected by turning off the Neutral Cable Switch. By doing this, the Auxiliary power supply is cut off from the utility. 6-slot cabinet and 10-slot cabinet doesn't need to disconnect the inner control neutral cable. The Inner Control Neutral Cable is located in the right of the maintenance bypass and is protected by the protective board, as is shown in Fig.5-1.

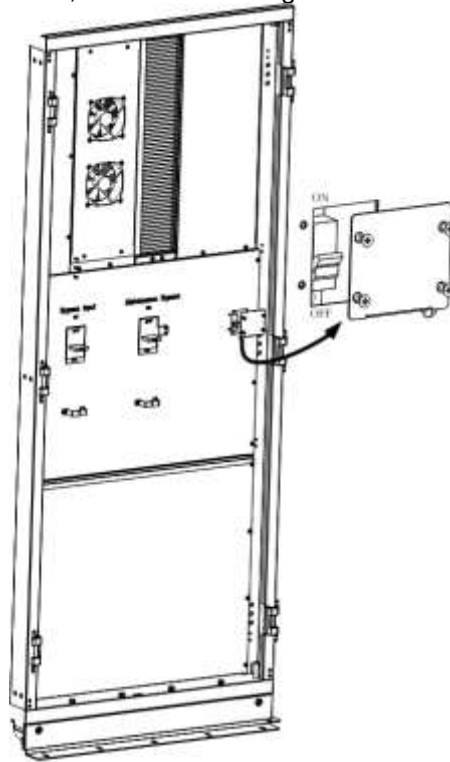

Fig.5-1 the position of Inner Control Neutral cable

5.4 Battery Setting

The setting of battery needs to be done after the first time of powering off or any changes done on the batteries.

The battery configuration can be done through the LCD control panel (Fig.5-2) or through monitoring software (Fig.5-3).

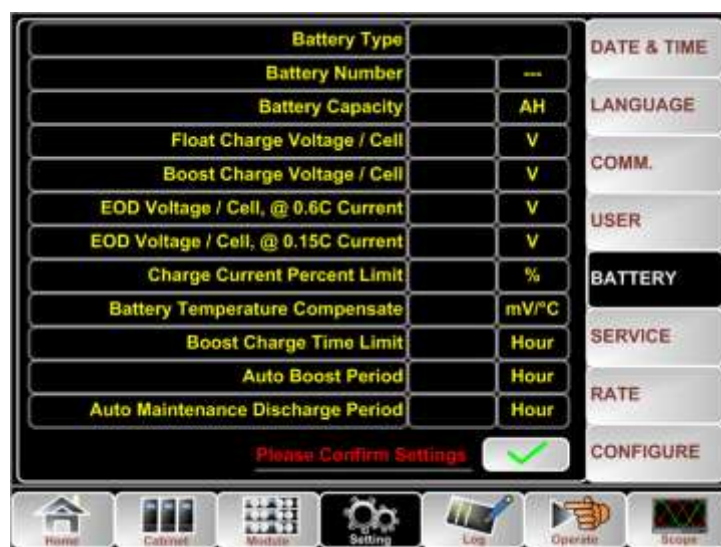

Fig.5-2 Configuration through LCD control panel

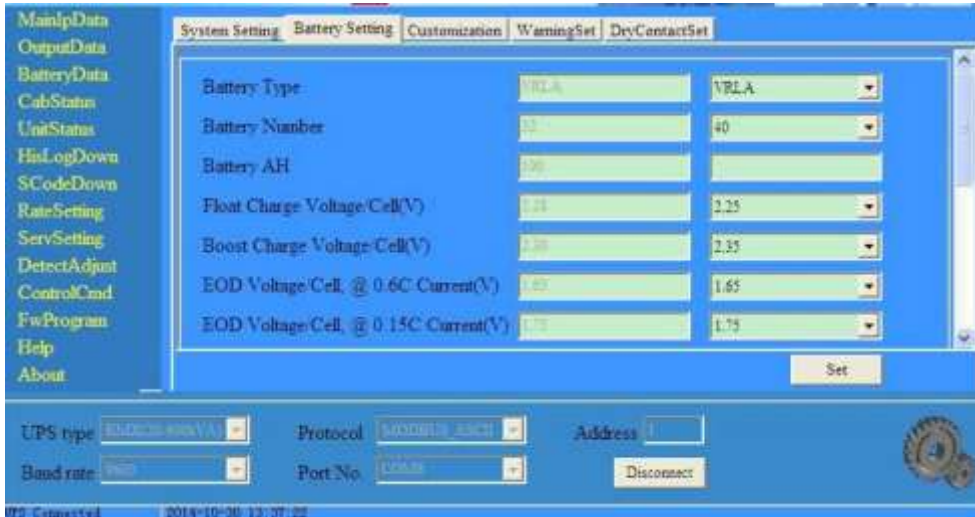

Fig.5-3 Configuration through monitoring software

5.4.1 Setting of Battery Type

The battery type can be only set through the monitoring software. The system at present supports lead acid battery and Lithium iron phosphate battery (LFPB).

5.4.2 Setting of Battery Number

1) Setting battery number for Lead- Acid battery

The nominal voltage of one block battery is 12V and for each block of battery, it consists of 6 cells (each cell of 2V). For the setting, as is shown in Fig.5-2, if the battery is 40, it means that there are 40 blocks of batteries and both the positive and negative are 20 blocks of batteries. In the case of cell battery of 2V (usually with large capacity) is used, battery number should be the same as the block battery. The cell battery actually in use should be 240 cells (6*40), with both and positive and negative of 120 cells.

The battery number setting range is 36-44

2) Setting battery number for LFPB

For the cell of each LFPB, the cell voltage is 3.2V; each battery block consists of 1 cell. In total, if 40 blocks of Lead- Acid battery are used, for the LFPB, the number will be 150. Both the positive and negative are 75 cells.

The battery number setting range is 140-180. The lowest EOD voltage for the LFPB will be 360V and highest voltage can be 620V.

5.4.3 Battery Capacity Setting

Battery Capacity Setting sets the capacity value of the battery block. For example, if the system uses 40 blocks of 12V/100AH batteries, the Battery Capacity Setting should set to 100 Ah. If 240 cells of 2V/1000AH are used, the Battery Capacity Setting should be set to 1000 Ah.

In case of there are more than one strings of battery in parallel, the battery capacity setting value will be the times of the single string. For instance, if the configuration is two strings of 40 blocks of 12V/100AH batteries, the battery capacity setting should be set to 200AH.

The system sets current limits according to the battery capacity set. For the Lead-Acid battery, the current limit is 0.2C, and for the LIPB, the current is 0.3C. For instance, the 20-slot UPS is configured to 40 blocks of 12V/500AH batteries, which can provides total max charging current of 192A. Due to the current limits(0.2C), the max charging current will be 100A(0.2*500A).

5.4.4 Float and Boost Charge Setting

In boos charging, the system charges the batteries with constant current. After the period, the system will enter the float charging.

For the Lead-Acid battery, the default float charge voltage per cell is 2.25V, boost charge voltage is 2.35V ;

For the LFPB, the default float and boost charge voltage per cell is 3.45V

5.4.5 EOD Voltage Setting

The EOD voltage 0.6C is the EOD voltage when the discharging current is larger than 0.6C; EOD voltage 0.15C is the EOD voltage when the discharging current is less than 0.15C. EOD voltage decreases linearly as the EOD voltage Current increases from 0.15C to 0.6C, as shown in Fig.6-4.

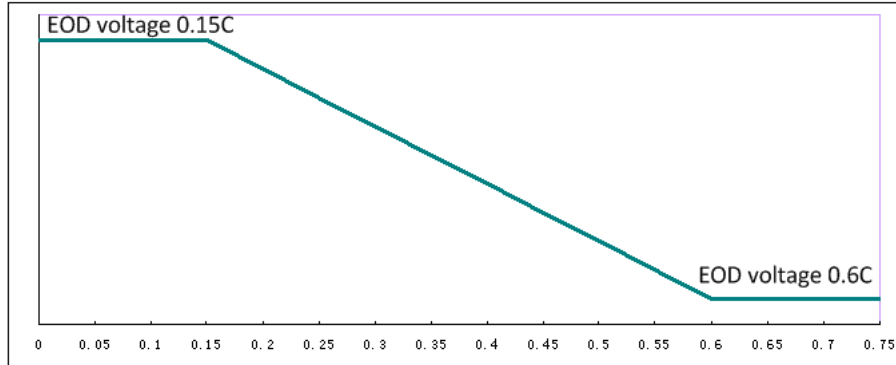

Fig.5-4 EOD voltage

For Lead-Acid battery, the cell voltage is suggested to set to 1.65V/cell at 0.6C, and set to 1.75V at 0.15C

For the LFPB battery, the cell voltage is suggested to set to 2.7V/cell at both 0.6C and 0.15C.

5.4.6 Charging Current Percent Limit

This setting is for limiting the charging power, max current limit can be 20% of the rated active power. The actual charging current is also limited to the battery capacity.

5.4.7 Battery Temperature Compensate

This is for setting the temperature compensate coefficient. Based on 25°C, when the temperature is higher than that, the discharging voltage goes lower; When the temperature is lower than that, the discharging voltage goes higher.

5.4.8 Boost Charge Time Limit

This is for setting the Boost Charge time. When the set time is up, the system transfers to float charge. The setting range can be 1-48h.

5.4.9 Auto Boost Period

This is for setting the Auto boost period time. When the set time is up, the system boost charges the battery. It is suggested to boost charge the battery every three month, set the period to 4320h.

5.4.10 Auto maintenance Discharge Period

When the Auto maintenance Discharge period is reached, the system discharges the battery. This function should be enabled by checking the AutoMaint (RateSetting->SysCodeSetting1) through the monitoring software, as shown in Fig.5-5.



Fig.5-5 Enable the Auto maintenance Discharge period

The EOD voltage of Auto maintenance Discharge is 1.05 times of the normal EOD voltage.

5.4.11 Warnings for Battery and Environment Temperature Overheat

This function can be set through the monitoring software. The system will read the temperature information of the battery and environment and give warning of overheat.

The set range is 25-70 °C.

The temperature sensor should be placed through the Dry Contact.

5.5 Replacing Dust Filter (optional)

As shown in Fig.5-6, there are 3~4 dust filters on the back of UPS' front door, each filter is held in place by a bracket on either side of each filter. The procedure of replacing each filter is as follows:

1. Open the front door and locate the filters on the back side of the front door.
2. Remove one bracket.
3. Remove the dust filter to be replaced and insert the clean one.
4. Reinstall the bracket.

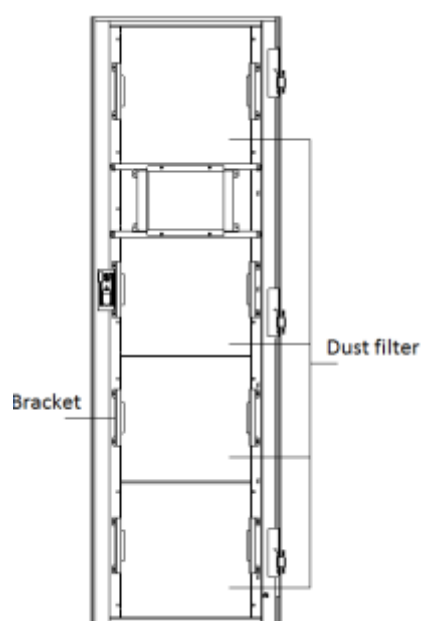

Fig. 5-6 Dust filter on the back side of front door

Chapter 6 Product Specification

This chapter provides the specifications of the product, including environmental characteristics mechanical characteristics and electrical characteristics.

6.1 Applicable Standards

The UPS has been designed to conform to the following European and international standards:

Table 6.1 Compliance with European and International Standards

Item	Normative reference
General safety requirements for UPS used in operator access areas	EN50091-1-1/IEC62040-1-1/AS 62040-1-1
Electromagnetic compatibility (EMC) requirements for UPS	EN50091-2/IEC62040-2/AS 62040-2 (C3)
Method of specifying the performance and test requirements of UPS	EN50091-3/IEC62040-3/AS 62040-3 (VFI SS 111)

Note

The above mentioned product standards incorporate relevant compliance clauses with generic IEC and EN standards for safety (IEC/EN/AS60950), electromagnetic emission and immunity (IEC/EN/ AS61000 series) and construction (IEC/EN/AS60146 series and 60950).

6.2 Environmental Characteristics

Table 6.2 Environmental Characteristics

Item	Unit	Requirements		
		180kVA	300kVA	600kVA
Acoustic noise level at 1 meter	dB	65dB @ 100% load, 62dB @ 45% load		≤70dB
Altitude of Operation	m	≤1000,load derated 1% per 100m from 1000m to 2000m		
Relative Humidity	%	0-95,non condensing		
Operating Temperature	°C	0-40(for UPS only),Battery life is halved for every 10°C increase above 20°C		
UPS Storage Temperature	°C	-40-70		

6.3 Mechanical Characteristic

Table 6.3 Mechanical Characteristics for Cabinet

Item	Unit	180kVA	300kVA	600kVA
Mechanical Dimension (W*D*H)	mm	600*1100*1600	600*1100*2000	2000*1100*2000
Weight	kg	170	220	660
Color	N/A	Black		
Protection Level (IEC60529)	N/A	IP20		

Table 6.4 Mechanical Characteristics for Power Module

Item	Unit	30KVA
Mechanical Dimension, W*D*H	mm	460*790*134
Weight	kg	34

6.4 Electrical Characteristics

6.4.1 Electrical Characteristics (Input Rectifier)

Table 6.5 Rectifier AC input Mains

Item	Unit	Parameter
Grid System	\	3 Phases + Neutral + Ground
Rated AC Input Voltage	Vac	380/400/415 (three-phase and sharing neutral with the bypass input)
Rated Frequency	Hz	50/60Hz
Input voltage range	Vac	304~478Vac (Line-Line),full load 228V~304Vac (Line-Line),load decrease linearly according to the min phase voltage
Input Frequency range	Hz	40~70
Input Power factor	PF	>0.99
THDI	THDI%	<3% (full Linear Load)

6.4.2 Electrical Characteristics (Intermediate DC Link)

Table 6.6 Battery

Items	Unit	Parameters
Battery bus voltage	Vdc	Rated: $\pm 240V$
Quantity of lead-acid cells	Nominal	40=[1 battery(12V)] ,240=[1 battery(2V)]
Float charge voltage	V/cell (VRLA)	2.25V/cell(selectable from 2.2V/cell~2.35V/cell) Constant current and constant voltage charge mode
Temperature compensation	mV/°C/cl	3.0(selectable:0~5.0)
Ripple voltage	%	≤ 1
Ripple current	%	≤ 5
Equalized charge voltage	VRLA	2.4V/cell(selectable from : 2.30V/cell~2.45V/cell) Constant current and constant voltage charge mode
Final discharging voltage	V/cell (VRLA)	1.65V/cell(selectable from: 1.60V/cell~1.750V/cell) @0.6C discharge current 1.75V/cell (selectable from: 1.65V/cell~1.8V/cell) @0.15C discharge current (EOD voltage changes linearly within the set range according to discharge current)
Battery Charge	V/cell	2.4V/cell(selectable from : 2.3V/cell~2.45V/cell) Constant current and constant voltage charge mode
Battery Charging Power Max Current	kW	10%* UPS capacity (selectable from : 1~20% * UPS capacity)

6.4.3 Electrical Characteristics (Inverter Output)

Table 6.7 Inverter Output (To critical load)

Item	Unit	Value
Rated capacity	kVA	180/300/600
Rated AC voltage	Vac	380/400/415 (Line-Line)
Rated Frequency	Hz	50/60
Frequency Regulation	Hz	50/60Hz $\pm 0.1\%$
Voltage precision	%	$\pm 1.5(0\sim 100\%$ linear load)
Overload	\	110%, 60min; 125%, 10min; 150%, 1min; >150%, 200ms
Synchronized Range	Hz	Settable, $\pm 0.5Hz \sim \pm 5Hz$, default $\pm 3Hz$
Synchronized Slew Rate	Hz	Settable, 0.5Hz/S \sim 3Hz/S, default 0.5Hz/S
Output Power Factor	PF	0.9
Transient Response	%	<5% for step load (20% - 80% -20%)
Transient recovery		< 30ms for step load (20% - 100% -20%)
Output Voltage THDu		<1% from 0% to 100% linear load <6% full non-linear load according to IEC/EN62040-3

6.4.4 Electrical Characteristics (Bypass Mains Input)

Table 6.8 Bypass Mains Input

Item	Unit	180	300	600
Rated AC voltage	Vac	380/400/415 (three-phase four-wire)		
Rated AC Current	A	273	454	909
Overload	%	110% Long term operation 110%~125% for 5min 125%~150% for 1min 150%~400% for 1s >400% ,less than 200ms		
Current rating of neutral cable	A	1.7×In		
Rated frequency	Hz	50/60		
Switch time (between bypass and inverter)	ms	Synchronized transfer: 0ms		
Bypass voltage range	%\	Settable, default -20%~+15% Up limited: +10%, +15%, +20%, +25% Down limited: -10%, -15%, -20%, -30%, -40%		
Bypass frequency range	%Hz	Settable, ±1Hz, ±3Hz, ±5Hz		
Synchronized Range	Hz	Settable ±0.5Hz~±5Hz, default ±3Hz		

6.5 Efficiency

Table 6.9 Efficiency

System Efficiency		
Normal mode(dual conversion)	%	>95
Battery discharging efficiency (battery at nominal voltage 480Vdc and full-rated linear load)		
battery mode	%	>95

6.6 Display and Interface

Table 6.10 Display and Interface

Display	LED + LCD +Color touch screen
Interface	Standard:RS232, RS485, USB, Dry Contact Option: SNMP,AS/400

Chapter 7. Contacts

If there have any technical problems with the product, please contact the installer or CyberPower. During inquiring, please provide the below information:

1. Model Name
2. Serial Number
3. Detailed Issue Description

Taiwan, United Kingdom

Cyber Power Systems, Inc.

11F., No.26, Jinzhuang Rd., Neihu Dist., Taipei City 114, Taiwan

Tel: +886 2 8792 9510

Fax: +886 2 8792 9621

Email: tw.service@cyberpower.com, uk.service@cyberpower.com

Europe, Northern Ireland

Cyber Power Systems B.V.

Flight Forum 3545, 5657DW Eindhoven, The Netherlands

Tel: +31 40 2348170

Fax: +31 40 2340314

Email: eu.service@cyberpower.com

Austria, Germany, Switzerland

Cyber Power Systems GmbH

Edisonstrasse 16, 85716 Unterschleissheim, Germany

Telefon: +49 89 1 222 166 0

Fax: +49 89 1 222 166 29

Email: de.service@cyberpower.com

France

Nitram S.A.

Z.I. Saint-Séverin, 28220 CLOYES, FRANCE

Tél : +33 2 37 98 61 50

Fax: +33 2 37 98 60 04

E-mail: infos@nitram.fr

All Other Regions

Please visit our website for local contact information

Note

CyberPower

www.CyberPower.com

V1.0.2