

MV-CL086-91GC

8192 P CMOS GigE Line Scan Camera



GEN*i*CAM

GigE
VISION

Introduction

MV-CL086-91GC camera adopts CMOS sensor to provide high-quality image, and uses GigE interface to transmit images in real time. It adopts multiple ISP image algorithms and functions, and supports external trigger modes like line trigger, frame trigger, and trigger-width exposure.

Key Feature

- Supports image compression mode, TDI, trigger-width exposure, RGB true color etc.
- Supports manual adjustment for Gamma correction, white balance, PRNUC correction, LUT, black level, space correction, etc.
- Adopts bi-directional I/O hardware design.
- Compact design and flexible installation.
- Compatible with GigE Vision V2.0 and GenICam standard.

Available Model

MV-CL086-91GC

Applicable Industry

Printing, textiles, railway, logistics, metallurgy, food, pharmaceutical manufacturing, material sorting, etc.

Sensor Quantum Efficiency

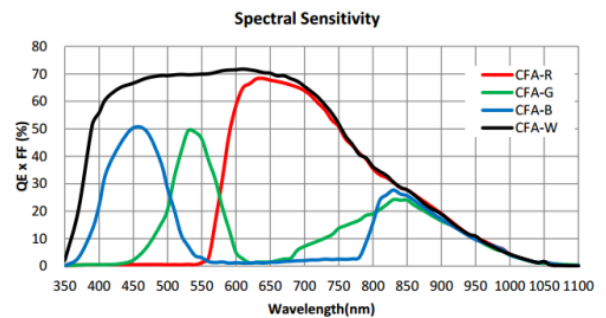

Dimension

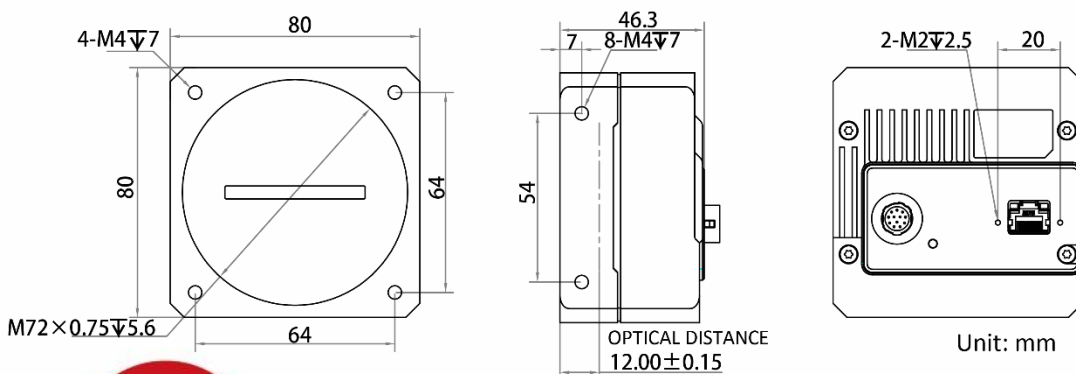

Specification

Model	MV-CL086-91GC
Camera	
Sensor type	CMOS
Pixel size	5 μ m
Resolution	8192 \times 6
Image mode	Supports 1-line, 2-TDI
Max. line rate	14 kHz @Bayer 8/Mono 8, 7 kHz @Bayer 10/Mono 10, 4.7 kHz @RGB 8/BGR 8 Image compression mode: 40 kHz @Bayer 8, 20 kHz @Bayer 10, 14 kHz @RGB 8
Dynamic range	54.8 dB
SNR	40.3 dB
Gain	Supports 1.2 \times , 2.7 \times , 4.6 \times
Exposure time	3 μ s to 10 ms
Exposure mode	Off/ Once/ Continuous exposure mode, and supports trigger-width exposure
Mono/color	Color
Pixel format	Mono 8/10, Bayer RG 8/10, RGB 8, BGR 8
Binning	Not support
Reverse image	Supports horizontal reverse image output
Trigger mode	External trigger, internal trigger
External trigger mode	Line trigger, frame trigger, line + frame trigger
Electrical feature	
Data interface	Gigabit Ethernet, compatible with Fast Ethernet
Digital I/O	12-pin Hirose connector provides power and I/O: configurable input or output \times 4 (Line 0/1/3/4) and support single-ended/differential
Power supply	12 VDC to 24 VDC
Power consumption	Typ. 13.0 W@12 VDC
Mechanical	
Lens mount	M72 *0.75, optical back focal length: 12 mm (0.5")
Dimension	80 mm \times 80 mm \times 46.3 mm (3.1" \times 3.1" \times 1.8")
Weight	Approx. 465 g (1.0 lb.)
Ingress protection	IP40 (under proper lens installation and wiring)
Temperature	Working temperature: -20 $^{\circ}$ C to 55 $^{\circ}$ C (-4 $^{\circ}$ F to 131 $^{\circ}$ F) Storage temperature: -30 $^{\circ}$ C to 80 $^{\circ}$ C (-22 $^{\circ}$ F to 176 $^{\circ}$ F)
Humidity	5% to 90% RH, non-condensing
General	
Client software	MVS or the third-party software meeting with GigE Vision protocol
Operating system	32/64-bit Windows XP/7/10, 32/64-bit Linux, and 64-bit MacOS
Compatibility	GigE Vision V2.0, GenICam
Certification	CE, FCC, RoHS, KC

Distribution Partner:



SCORPION VISION