

MV-CH250-60TM

25 MP CMOS 10 GigE Area Scan Camera



GEN*i*CAM

10GiGE
VISION

Introduction

MV-CH250-60TM camera adopts CMOS sensor to provide high-quality images with high resolution and low noise. It uses 10 GigE interface to transmit non-compressed data in real time, and its max. frame rate can reach 31.7 fps in full resolution.

Key Feature

- Resolution of 5120 × 5120, and pixel size of 4.5 μm × 4.5 μm.
- Supports auto or manual adjustment of exposure time, and manual adjustment of gain, Gamma correction, LUT, etc.
- Adopts 10 GigE interface, compatible with GigE, and max. transmission distance of 100 meters.
- Compact design with mounting holes on panels for flexible mounting.
- Compatible with GigE Vision V2.0 Protocol, GenlCam Standard, and third-party software based on the protocol and standard.

Dimension

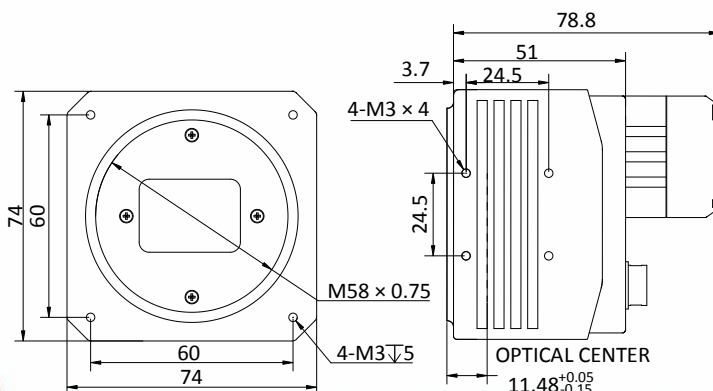

Available Model

MV-CH250-60TM-M58S-NF

Applicable Industry

PCB AOI, FPD detection, photovoltaics, railway related application, etc.

Sensor Quantum Efficiency

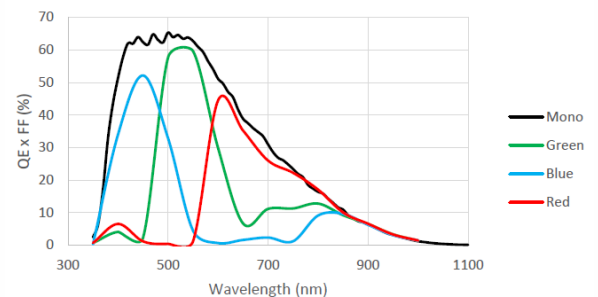

Unit: mm



Specification

Model	MV-CH250-60TM
Camera	
Sensor type	CMOS, global shutter
Pixel size	4.5 μm \times 4.5 μm
Sensor size	23 mm \times 23 mm
Resolution	5120 \times 5120
Max. frame rate	31.7 fps @5120 \times 5120 Mono 8
Dynamic range	66 dB
SNR	40 dB
Gain	0 dB to 15.6 dB
Exposure time	15 μs to 10 sec
Exposure mode	Off/Once/Continuous exposure mode
Mono/Color	Mono
Pixel format	Mono 8/10/10Packed/12/12Packed
Binning	Not support
Decimation	Not support
Reverse image	Supports horizontal and vertical reverse image output
Electrical feature	
Data interface	10 Gigabit Ethernet, compatible with Gigabit Ethernet
Digital I/O	12-pin P10 connector provides power and I/O, including opto-isolated input \times 1 (Line 0), opto-isolated output \times 1 (Line 1), bi-directional non-isolated I/O \times 1 (Line 2), RS-232 \times 1
Power supply	12 VDC to 24 VDC
Power consumption	Typ. 15.1 W@12 VDC
Mechanical	
Lens mount	M58-mount, flange back focal length: 11.48 mm (0.5")
Dimension	74 mm \times 74 mm \times 78.8 mm (2.9" \times 2.9" \times 3.1")
Weight	Approx. 550 g (1.2 lb)
Ingress protection	IP40 (under proper lens installation and wiring)
Temperature	Working temperature: 0 $^{\circ}\text{C}$ to 50 $^{\circ}\text{C}$ (32 $^{\circ}\text{F}$ to 122 $^{\circ}\text{F}$) Storage temperature: -30 $^{\circ}\text{C}$ to 70 $^{\circ}\text{C}$ (-22 $^{\circ}\text{F}$ to 158 $^{\circ}\text{F}$)
Humidity	20% to 95% RH, non-condensing
General	
Client software	MVS or third-party software meeting with GigE Vision Protocol
Operating system	32/64-bit Windows XP/7/10
Compatibility	GigE Vision V2.0, GenICam
Certification	CE, FCC, RoHS, KC



Hangzhou Hikrobot Co., Ltd.
en.hikrobotics.com

© Hangzhou Hikrobot Co., Ltd. All Rights Reserved.

Hangzhou Hikrobot does not tolerate any infringement. Any organization or individual may not imitate or reproduce in whole or in part of the content. The data herein is based on Hikrobot's internal evaluation. Actual data may vary depending on specific configuration and operating condition. The information herein is subject to change without notice. All the content has been checked conscientiously. Nevertheless, Hikrobot shall not be liable to damages resulting from errors, inconsistencies or omissions.