

MV-CB120-10UM/UC

12 MP 1/1.7" CMOS USB3.0 Board Level Camera



GEN*i*CAM

USB
VISION

Introduction

MV-CB120-10UM/UC camera adopts Sony® IMX226 sensor to provide high-quality image. With single board design, it is small in size, which can meet different spatial requirements.

Key Feature

- Compact design for flexible installation.
- Supports auto and manual adjustment for gain, exposure control, white balance, LUT, etc.
- Adopts image interpolation algorithm for color camera to have better color correction.
- Power supply and data transmission via USB3.0 interface.
- Compatible with USB3 Vision Protocol, GenlCam standard, and the third-party software based on these protocol and standard.

Available Model

- Single board mono camera: MV-CB120-10UM-B
- Single board color camera: MV-CB120-10UC-B
- C-mount mono camera: MV-CB120-10UM-C
- C-mount color camera: MV-CB120-10UC-C
- M12-mount mono camera: MV-CB120-10UM-S
- M12-mount color camera: MV-CB120-10UC-S

Sensor Quantum Efficiency

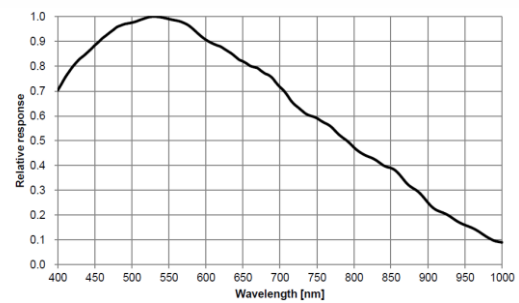

MV-CB120-10UM-B

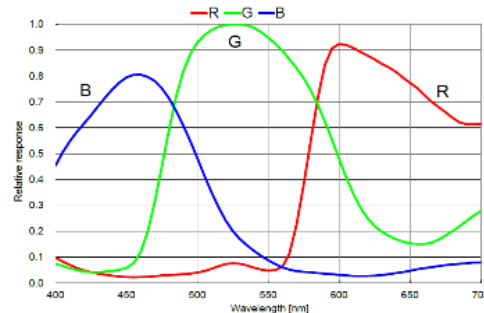

MV-CB120-10UC-B

Applicable Industry

Electronic semiconductor, factory automation, logistics, liquor and beverage, medicine packing, etc.



Specification

Model	MV-CB120-10UM	MV-CB120-10UC
Camera		
Sensor type	CMOS, rolling shutter	
Sensor model	Sony® IMX226	
Pixel size	1.85 μm × 1.85 μm	
Sensor size	1/1.7"	
Resolution	4032 × 3036	
Max. frame rate	28 fps @4032 × 3036	21 fps @4032 × 3036
Dynamic range	70.5 dB	
SNR	40.5 dB	
Gain	0 dB to 20 dB	
Exposure time	11 μs to 2 sec	23 μs to 2 sec
Exposure mode	Supports Off/ Once/ Continuous exposure mode, and Global Reset.	
Mono/color	Mono	Color
Pixel format	Mono 8/10/10p/12/12p	Mono8/10/12, Bayer RG 8/10/10p/12/12p YUV 422 Packed, YUV422_YUYV_Packed, RGB 8
Binning	Not support	
Decimation	Supports 1 × 1, 1 × 2, 2 × 1, 2 × 2	Not support
Reverse image	Supports horizontal and vertical reverse image output	
Electrical feature		
Data interface	USB3.0	
Digital I/O	Bi-directional non-isolated I/O x 2 (Line 1, Line 2)	
Power supply	USB3.0 power supply	
Power consumption	Typ. 2.45 W@5 VDC	
Mechanical		
Lens mount	Single board camera: none C-mount camera: C-mount M12-mount camera: M12-mount	
Dimension	Single board camera: 32.5 mm × 32.5 mm × 1.6 mm (1.3" × 1.3" × 0.1") C-mount camera: 35 mm × 35 mm × 8.6 mm (1.4" × 1.4" × 0.3") M12-mount camera: 35 mm × 35 mm × 8.6 mm (1.4" × 1.4" × 0.3")	
Weight	Single board camera: Approx. 10 g (0.02 lb.) C-mount camera: Approx. 30 g (0.07 lb.) M12-mount camera: Approx. 30 g (0.07 lb.)	
Temperature	Working temperature: 0 °C to 50 °C (32 °F to 122 °F) Storage temperature: -30 °C to 70 °C (-22 °F to 158 °F)	
Humidity	20% to 80% RH, non-condensing	
General		
Client software	MVS or third-party software with USB3 Vision Protocol	
Operating system	32/64-bit Windows XP/7/10, 32/64-bit Linux	
Compatibility	USB3 Vision, GenICam	
Certification	CE, FCC, RoHS, KC	

Dimension

Single board camera:

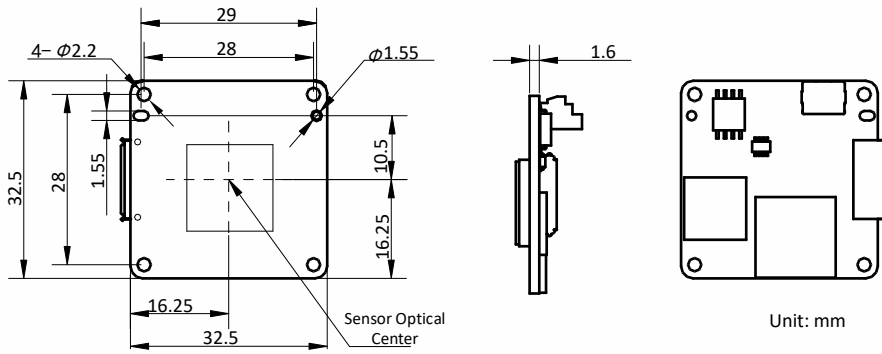

C-mount camera:

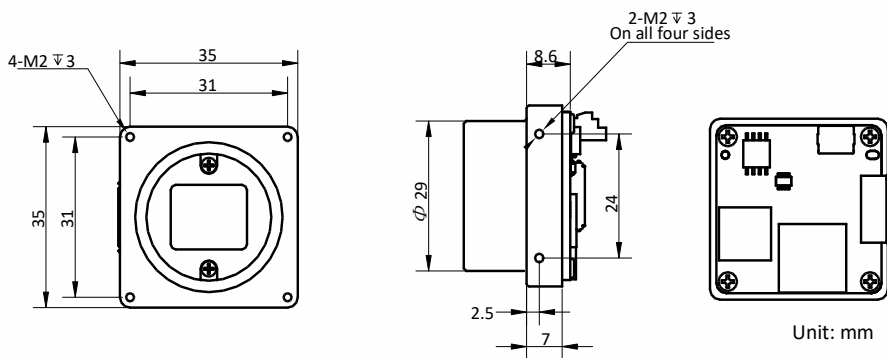

M12-mount camera:

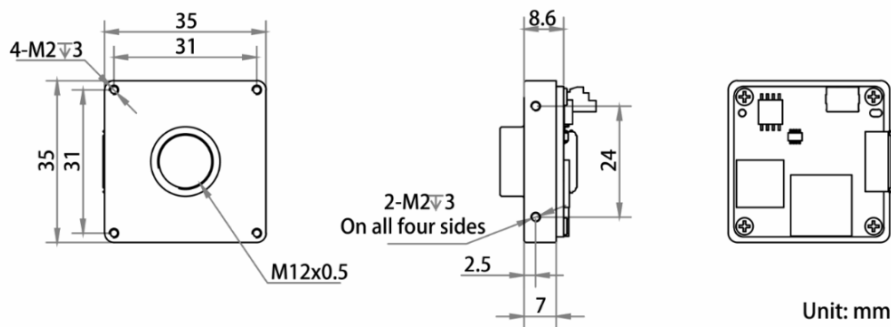

Distribution Partner:



SCORPION VISION