

# CyberPower®

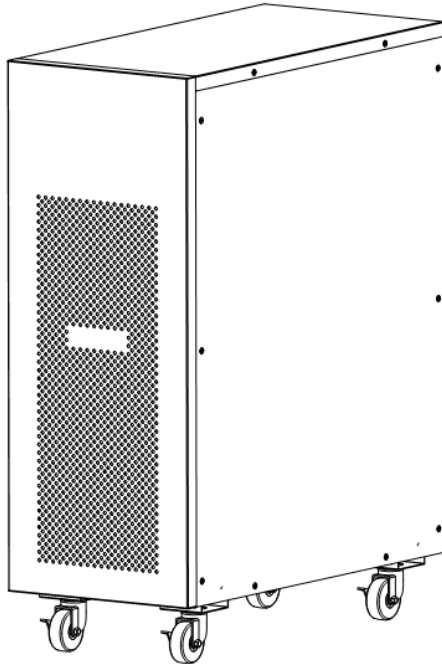

**BPSE240V47A**  
**BPSE240V47AOA**  
**User's Manual**

K01-C000048-03

## **SAFETY**

This manual contains important instructions. Please read and follow all instructions carefully during installation and operation of the unit. Read this manual thoroughly before attempting to unpack, install, or operate the Battery modules.

- **CAUTION!** The UPS unit must be connected to a grounded AC power outlet with fuse or circuit breaker protection. The Battery modules grounded are through the UPS.
- **CAUTION!** The battery can power hazardous components inside the unit, even when the AC input power is disconnected.

- **CAUTION!** To prevent the risk of fire or electric shock, install in a temperature and humidity controlled indoor area, free of conductive contaminants. (Please see specifications for acceptable temperature and humidity range).
- **CAUTION! (No User Serviceable Parts):** Risk of electric shock, do not remove cover. No user serviceable parts inside. Refer servicing to qualified service personnel.
- **CAUTION! (Non-Isolated Battery Supply):** Risk of electric shock, battery circuit is not isolated from AC power source; hazardous voltage may exist between battery terminals and ground. Test before touching.
- **CAUTION!** Wiring must be done by qualified personnel.
- **CAUTION! DO NOT USE WITH OR NEAR AQUARIUMS!**



To reduce the risk of fire, do not use with or near aquariums. Condensation from the aquarium can come in contact with metal electrical contacts and cause the machine to short out.

- **CAUTION!** Do not dispose of batteries in fire as the battery may explode.
- **CAUTION!** Do not open or mutilate the battery, released electrolyte is harmful to the skin and eyes.
- **CAUTION!** A battery can present a risk of electric shock and high short circuit current. The following precaution should be observed when working on batteries
  1. Remove watches, rings or other metal objects.
  2. Use tools with insulated handles.
- **CAUTION!** Make sure everything is turned off and disconnected completely before conducting any maintenance, repairs or shipment.
- **CAUTION!** Connect the Protection Earth (PE) safety conductor before any other cables are connected.
- **DO NOT INSTALL THE UNIT WHERE IT WOULD BE EXPOSED TO DIRECT SUNLIGHT OR NEAR A STRONG HEAT SOURCE!**
- **SERVICING OF BATTERIES SHOULD BE PERFORMED OR SUPERVISED BY PERSONNEL KNOWLEDGE OF BATTERIES AND THE REQUIRED PRECAUTIONS. KEEP UNAUTHORIZED PERSONNEL AWAY FROM BATTERIES!**

## UNPACKING

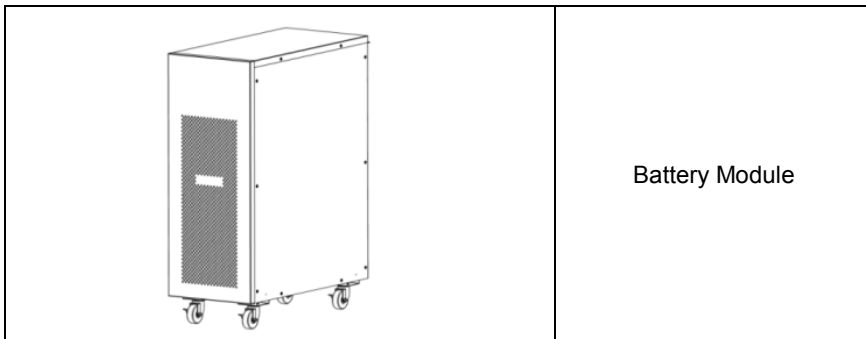
The box should contain the following:



	<p>Battery Cable</p>
	<p>User's manual</p>

**BASIC OPERATION**

**SCHEMATIC**

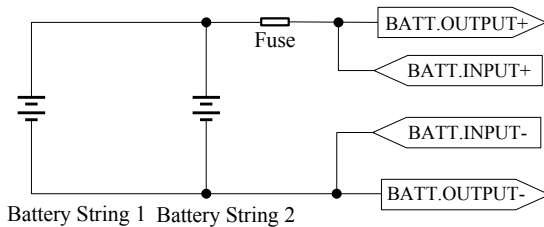

**FRONT/REAR PANEL DESCRIPTION**

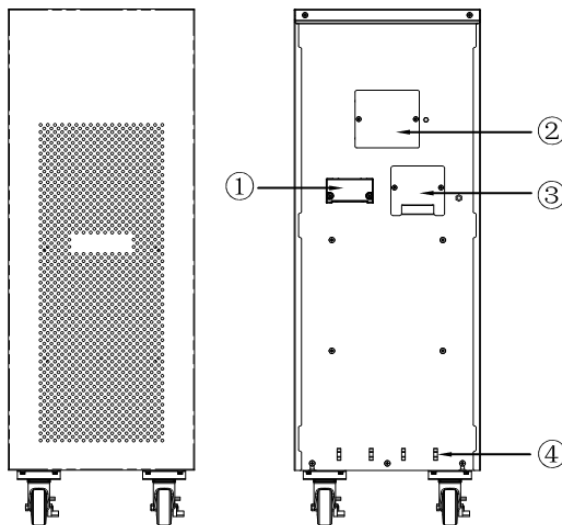

①. **Output Connector:** Use this output connector to connect the Battery module

and the Power module.

②. **On-board Replaceable Fuse Cover:** Replaceable fuse is accessible from the rear panel. It must be done by qualified personnel.

③. **Battery input Terminal Block:** Use this input Terminal Block to daisy chain the next Battery module.

④. **Self- locking Frame**

**CONNECTION#1: POWER MODULE(UPS) WITH ONE BATTERY MODULE**

Step 1: Connect the Battery Cable to the Power module and ensure the polarity is right.

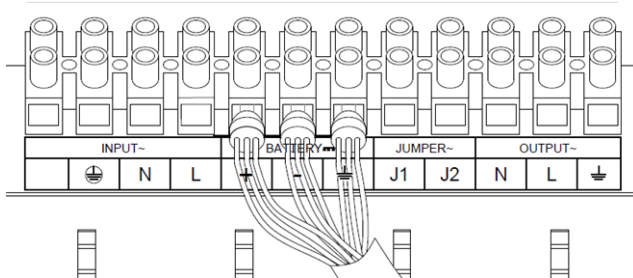

Step 2: Loosen the screws to remove the battery cable retention bracket of the Battery module.

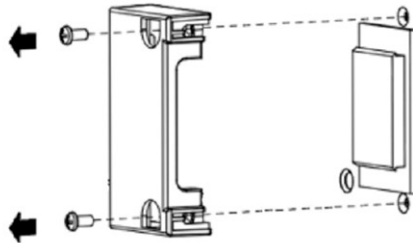

Step 3: Connect the Battery Cable to the Battery module.

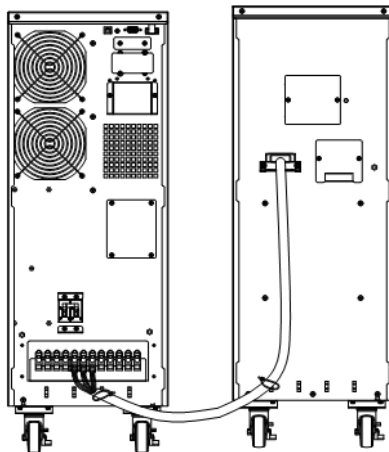

Step 4: Rotate the battery cable retention bracket and tighten the screws to fix battery cable.

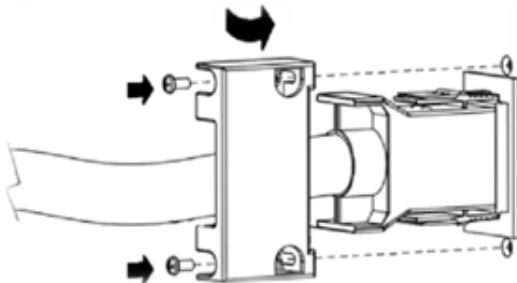

### **CONNECTION#2: POWER MODULE(UPS) WITH MULTIPLE BATTERY MODULES**

Step 1: Loosen the screws to remove the input Terminal Block Cover of the #1 battery module.

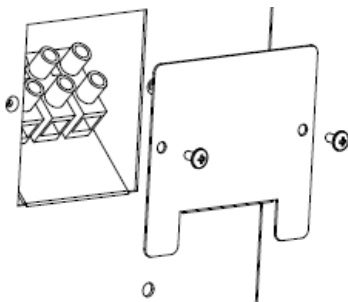

Step 2: Connect the Battery Cable to the battery input Terminal Block and ensure the polarity is right, then retighten the Block Cover.

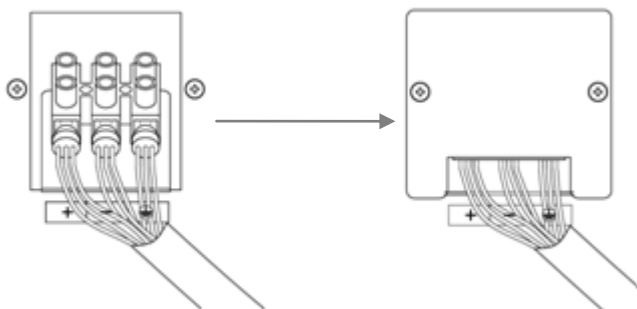

Step 3: Loosen the screws to remove the battery cable retention bracket of the #2 battery module.

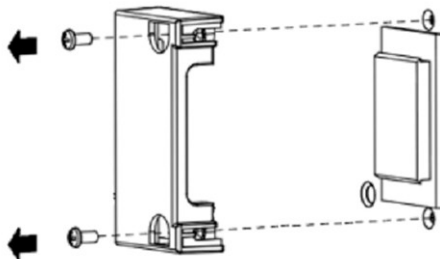

Step 4: Connect the #1 Battery module to the #2 Battery module.

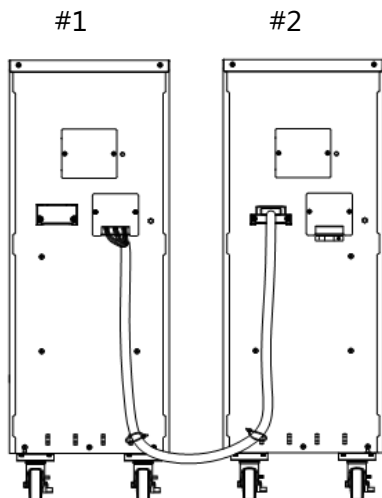

Step 5: Rotate the battery cable retention bracket and tighten the screws to fix battery cable.

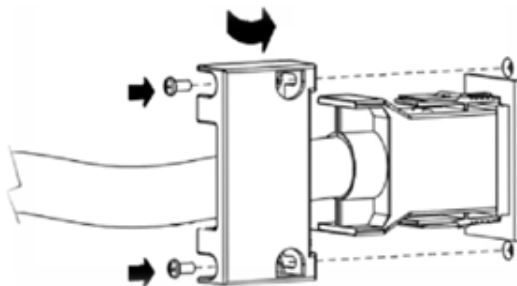

Step 6: Connect the #1 Battery module to the Power module. (Refer to above steps of connection#1)

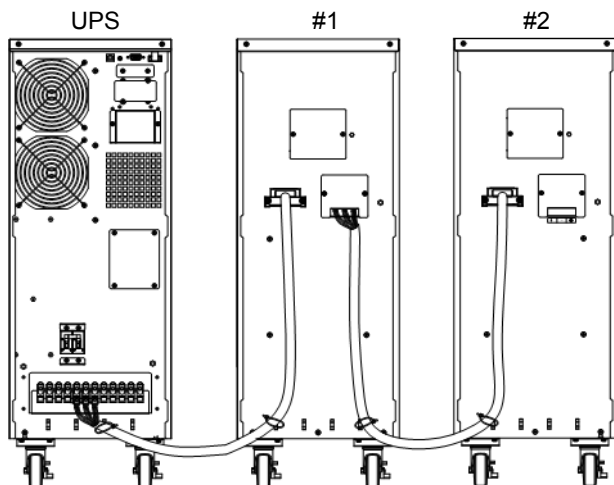

## TECHNICAL SPECIFICATION

Model	BPSE240V47A	BPSE240V47AOA
<b>Battery</b>		
Sealed Maintenance Free Lead Acid Battery	12V / 7Ah x20pcs x2sets	12V / 9Ah x20pcs x2sets
Rated Battery Voltage	240Vdc	
Overload Protection	Fuse	
<b>Physical</b>		
Maximum Dimensions (HxWxD) (mm)	718x260x550	
Weight (kg)	105	127
<b>Environment</b>		
Operating Temperature	0°C to 40°C	
Relative Humidity	0 to 90%(Non-condensing)	

CyberPower Systems Inc.

[www.cyberpower.com](http://www.cyberpower.com)

6F, No. 32, Sec. 1, Chenggong Rd., Nangang District, Taipei 115, Taiwan

Entire contents copyright© 2013 CyberPower Systems Inc., All rights reserved. Reproduction in whole or in part without permission is prohibited. PowerPanel® Business Edition and PowerPanel® Personal Edition are trademarks of CyberPower Systems Inc.

