

MV-CH120-11CM

12 MP 1.1" CMOS Camera Link Area Scan Camera



GEN*i*CAM



Introduction

MV-CH120-11CM camera adopts Sony® IMX304 sensor to provide high-quality image. It uses Camera Link interface to transmit non-compressed images in real time, and its max. frame rate can reach 23.4 fps in full resolution.

Key Feature

- Adopts global shutter CMOS sensor providing wide dynamic range and high-quality image.
- Supports configuration modes of Base and Medium via the Camera Link interface.
- Adopts compact design with mounting holes for flexible mounting.
- Compatible with Camera Link V2.0 Protocol, GenICam Standard, and the third-party software based on the protocol and standard.

Available Model

MV-CH120-11CM

Applicable Industry

SMT/ PCB AOI, FPD, 3D SPI, high-accuracy measurement, etc.

Sensor Quantum Efficiency

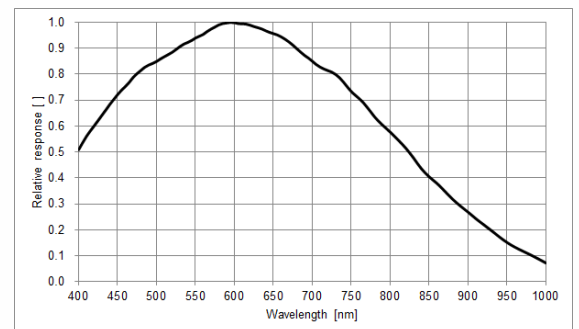

Dimension

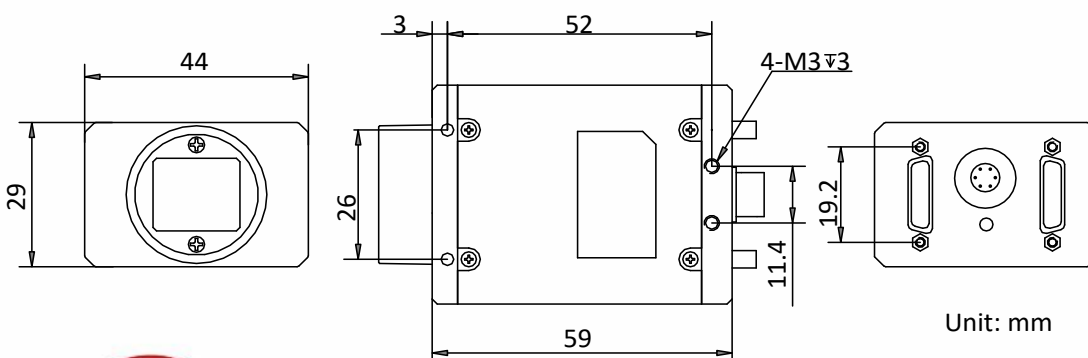

Specification

Model	MV-CH120-11CM	
Camera		
Sensor type	Global shutter CMOS	
Sensor model	Sony® IMX304	
Pixel size	3.45 μm × 3.45 μm	
Sensor size	1.1"	
Resolution	4096 × 3000	
Configuration mode	Base	Medium
Tap geometry	1X2_1Y	1X4_1Y
Tap number	2 Taps	4 Taps
Max. frame rate	13.2 fps @4096 × 3000	23.4 fps @4096 × 3000
Pixel clock	40 MHz, 66 MHz, 85 MHz	
Dynamic range	72 dB	
SNR	40.2 dB	
Gain	0 dB to 24 dB	
Exposure time	UltraShort exposure mode: 1 μs to 14 μs Standard exposure mode: 15 μs to 10 sec	
Mono/color	Mono	
Pixel format	Mono 8/10/12	
Exposure mode	Off/Once/Continuous exposure mode	
Binning	Supports 1 × 1, 1 × 2, 1 × 4, 2 × 1, 2 × 2, 2 × 4, 4 × 1, 4 × 2, 4 × 4	
Decimation	Supports 1 × 1, 1 × 2, 2 × 1, 2 × 2	
Reverse image	Supports horizontal and vertical reverse image output	
Electrical feature		
Data interface	Camera Link with SDR interface	
Digital I/O	6-pin Hirose connector provides power and I/O, including opto-isolated input × 1 (Line 0), opto-isolated output × 1 (Line 1), and bi-directional non-isolated I/O × 1 (Line 2).	
Power supply	9 VDC to 24 VDC	
Power consumption	Typ. 3.48 W@12 VDC	
Mechanical		
Lens mount	C-mount	
Dimension	44 mm × 29 mm × 59 mm (1.7" × 1.1" × 2.3")	
Weight	Approx. 100 g (0.2 lb.)	
Ingress protection	IP30 (under proper lens installation and wiring)	
Temperature	Working temperature: 0 °C to 50 °C (32 °F to 122 °F) Storage temperature: -30 °C to 70 °C (-22 °F to 158 °F)	
Humidity	20% to 80% RH, non-condensing	
General		
Client software	MVS or frame grabber software meeting with GenICam Protocol	
Operating system	32/64-bit Windows XP/7/10	
Compatibility	Camera Link V2.0, GenICam	
Certification	CE, FCC, RoHS, KC	

HIKROBOT

Hangzhou Hikrobot Technology Co., Ltd.

No.399 Danfeng Road, Binjiang District, Hangzhou 310051, China.

en.hikrobotics.com

Copyright Hikrobot

Hangzhou Hikrobot Technology Co., Ltd. All Rights Reserved. Hangzhou Hikrobot Technology does not tolerate any infringement. Any organization or individual may not imitate or reproduce in whole or in part of the content. The data herein is based on Hikrobot's internal evaluation. Actual data may vary depending on specific configuration and operating condition. The information herein is subject to change without notice. All the content has been checked conscientiously. Nevertheless, Hikrobot shall not be liable to damages resulting from errors, inconsistencies or omissions.