

MV-CL024-91GM

2048 P CMOS GigE Line Scan Camera



GEN*i*CAM

GigE VISION

Introduction

MV-CL024-91GM camera adopts CMOS sensor to provide high-quality images and integrates multiple ISP image algorithms and functions. It supports line trigger, frame trigger, line + frame trigger, etc. It uses GigE interface to transmit images in real time and its max. line rate can reach 86 kHz in high-bandwidth mode.

Key Feature

- Supports TDI and image high-bandwidth function.
- Supports Gamma correction, FFC correction, LUT, black level, etc.
- Adopts bi-directional I/O and flexible configuration for input/output signals.
- Supports flexible installation from different sides.
- Compatible with GigE Vision V2.0 protocol and GenICam standard.

Available Model

MV-CL024-91GM

Applicable Industry

Photovoltaics, lithium battery, railway, textiles, logistics, metallurgy, material sorting, etc.

Sensor Quantum Efficiency

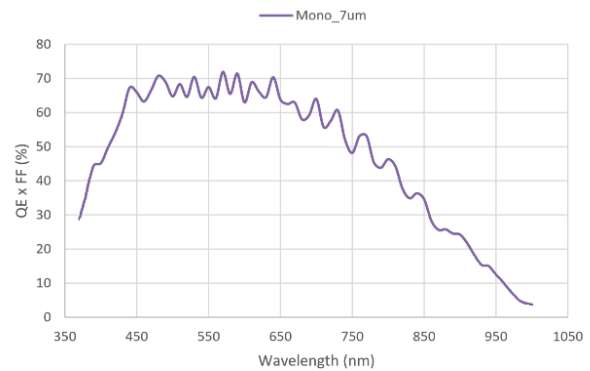

Dimension

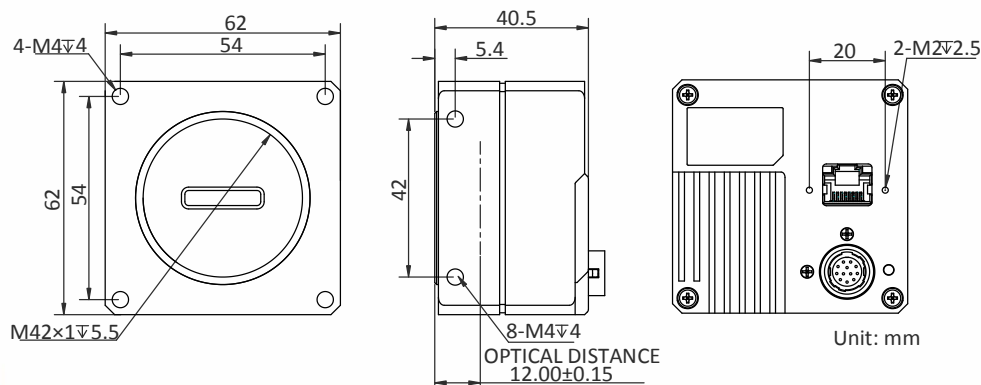

Specification

Model	MV-CL024-91GM
Camera	
Sensor type	CMOS
Pixel size	7 μm
Resolution	2048 \times 2
Image mode	Supports 1-line, 2-TDI
Max. line rate	Standard mode: 58 kHz @Mono 8, 29 kHz @Mono 10/12 High-bandwidth mode: 86 kHz @Mono 8, 58 kHz @Mono 10/12
Dynamic range	68 dB
SNR	44.7 dB
Gain	Supports 1.0 \times
Exposure time	3 μs to 10 ms
Exposure mode	Off/ Once/ Continuous exposure mode, and supports trigger-width exposure
Mono/color	Mono
Pixel format	Mono 8/10/12
Binning	Supports 1 \times 1, 2 \times 2, 4 \times 4
Reverse image	Supports horizontal reverse image output
Trigger mode	External trigger, internal trigger
External trigger mode	Line trigger, frame trigger, line + frame trigger
Electrical feature	
Data interface	Gigabit Ethernet, compatible with Fast Ethernet
Digital I/O	12-pin P10 connector provides power supply and I/O: configurable output and input \times 4 (Line 0/1/3/4), supports single-end/differential
Power supply	12 VDC to 24 VDC, supports PoE
Power consumption	Typ. 5.2 W @12 VDC
Mechanical	
Lens mount	M42 *1.0, optical back focal length: 12 mm (0.5"), applicable to F-mount, C-mount and others via lens adapter
Dimension	62 mm \times 62 mm \times 40.5 mm (2.4" \times 2.4" \times 1.6")
Weight	Approx. 256 g (0.6 lb.)
Ingress protection	IP40 (under proper lens installation and wiring)
Temperature	Working temperature: -20 $^{\circ}\text{C}$ to 55 $^{\circ}\text{C}$ (-4 $^{\circ}\text{F}$ to 131 $^{\circ}\text{F}$) Storage temperature: -30 $^{\circ}\text{C}$ to 80 $^{\circ}\text{C}$ (-22 $^{\circ}\text{F}$ to 176 $^{\circ}\text{F}$)
Humidity	5% to 90% RH, non-condensing
General	
Client software	MVS or the third-party software meeting with GigE Vision protocol
Operating system	32/64-bit Windows XP/7/10, 32/64-bit Linux, and 64-bit MacOS
Compatibility	GigE Vision V2.0, GenICam
Certification	CE, FCC, RoHS, KC

Distribution Partner:



**SCORPION
VISION**