

MV-CL042-91GMGC

4096 P CMOS GigE Line Scan Camera



GEN*i*CAM

GigE
VISION

Introduction

MV-CL042-91GMGC camera adopts CMOS sensor to provide high-quality image and integrates multiple ISP image algorithms and functions. It supports several external trigger modes such as line trigger, frame trigger, and line + frame trigger, etc. It uses GigE interface to transmit images in real time and their max. line rate can reach 80 kHz in the high-bandwidth mode.

Key Feature

- Supports image high-bandwidth mode, TDI, trigger-width exposure, etc.
- Supports manual adjustment for Gamma correction, PRNU correction, LUT, black level offset, etc.
- Adopts bi-directional I/O connection, flexible configuration for Input/Output.
- Compact design and flexible installation.
- Compatible with GigE Vision V2.0 and GenICam standard.

Available Model

MV-CL042-91GM
MV-CL042-91GC

Applicable Industry

Printing, textiles, railway, logistics, metallurgy, food, pharmaceutical manufacturing, material sorting, etc.

Sensor Quantum Efficiency

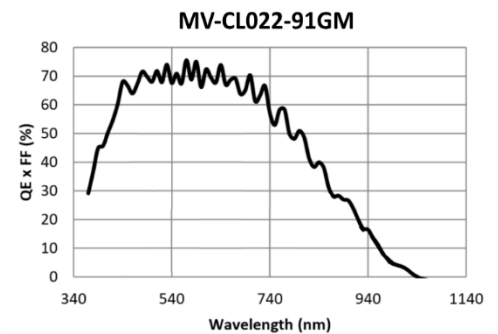
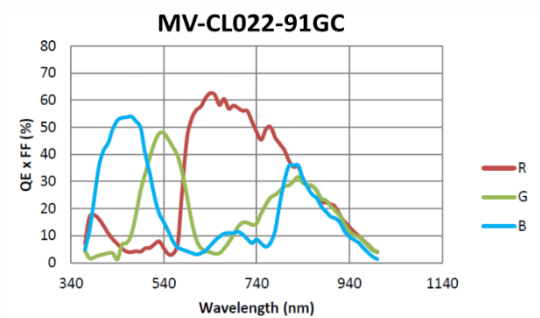

Dimension

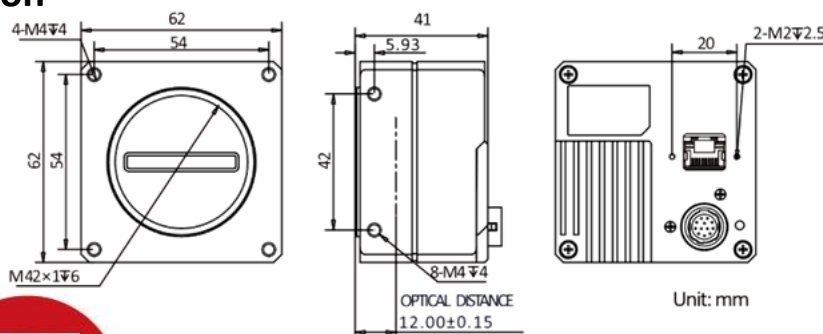

Specification

Model	MV-CL042-91GM	MV-CL042-91GC
Camera		
Sensor type	CMOS	
Pixel size	7 μm	
Resolution	4096 × 2	
Image mode	Supports 1 Line/2 TDI	Not support
Max. line rate	80 kHz @Mono 8/10/12 (HB) 28 kHz @Mono 8 (Non-HB) 14 kHz @Mono 10/12 (Non-HB)	80 kHz @Bayer RBGG 8 (HB) 40 kHz @Other pixel formats (HB) 19 kHz @Mono 8/Bayer RG 8/Bayer RBGG 8 (Non-HB) 14 kHz @Mono 10/12/Bayer RG 10/Bayer RG 12 (Non-HB) 9 kHz @RGB 8/BGR 8 (Non-HB)
Dynamic range	65.6 dB	
SNR	40 dB	
Gain	Supports 1.0 ×, 1.4 ×, 1.6 ×, 2.4 ×, 3.2 ×	
Exposure time	5 μs to 10 ms	
Exposure mode	Off/ Once/ Continuous exposure mode, and supports trigger-width exposure	
Mono/color	Mono	Color
Pixel format	Mono 8/10/12	Mono 8/10/12, Bayer RG 8/10/12, RGB 8, BGR 8, Bayer RBGG 8
Binning	Supports 1 × 1, 1 × 2, 1 × 4, 2 × 1, 2 × 2, 2 × 4, 4 × 1, 4 × 2, 4 × 4	
Reverse image	Supports horizontal reverse image output	
Trigger mode	External trigger, internal trigger	
External trigger mode	Line trigger, frame trigger, line + frame trigger	
Electrical feature		
Data interface	Gigabit Ethernet, compatible with Fast Ethernet	
Digital I/O	12-pin Hirose connector provides power and I/O: configurable output and input × 4 (Line 0/1/3/4), supports single-end/differential	
Power supply	12 VDC to 24 VDC, supports PoE	
Power consumption	Typ. 5.8 W@12 VDC	Typ. 6.6 W@12 VDC
Mechanical		
Lens mount	M42 *1.0, optical back focal length: 12 mm (0.5"), applicable to F/C-mount and others via lens adapter	
Dimension	62 mm × 62 mm × 41 mm (2.4" × 2.4" × 1.6")	
Weight	Approx. 280 g (9.9 lb.)	
Ingress protection	IP40 (under proper lens installation and wiring)	
Temperature	Working temperature: -20 °C to 55 °C (-4 °F to 131 °F) Storage temperature: -30 °C to 80 °C (-22 °F to 176 °F)	
Humidity	5% to 90% RH, non-condensing	
General		
Client software	MVS or the third-party software meeting with GigE Vision protocol	
Operating system	32/64-bit Windows XP/7/10, 32/64-bit Linux, and 64-bit MacOS	
Compatibility	GigE Vision V2.0, GenICam	
Certification	CE, FCC, RoHS, KC	

Distribution Partner:



**SCORPION
VISION**