

# MV-CH250-90TM/TC

25 MP 1.1" CMOS 10 GigE Area Scan Camera



GEN*i*CAM

10GiGE  
VISION

## Introduction

MV-CH250-90TM/TC camera adopts Gpixel GMAX0505 sensor to provide high-quality image. It uses 10 GigE interface to transmit non-compressed image in real time, and its max. frame rate can reach 41.5 fps in full resolution.

## Key Feature

- Resolution of 5120 × 5120, pixel size of 2.5 μm × 2.5 μm.
- Adopts 10 GigE interface providing maximum transmission distance of 100 meters.
- Supports adjustment for exposure time, gain, Look-Up Table (LUT), Gamma correction, etc.
- Mounting holes on panels for flexible installation.
- Compatible with GigE Vision Protocol V2.0, GenICam Standard, and third-party software based on protocols.

## Available Model

- Mono M58-mount with fan: MV-CH250-90TM-M58S-NF
- Color M58-mount with fan: MV-CH250-90TC-M58S-NF
- Color C-mount with fan: MV-CH250-90TC-C-NF

## Applicable Industry

SMT/PCB AOI, FPD, railway related applications, photovoltaic industry, etc.

## Sensor Quantum Efficiency

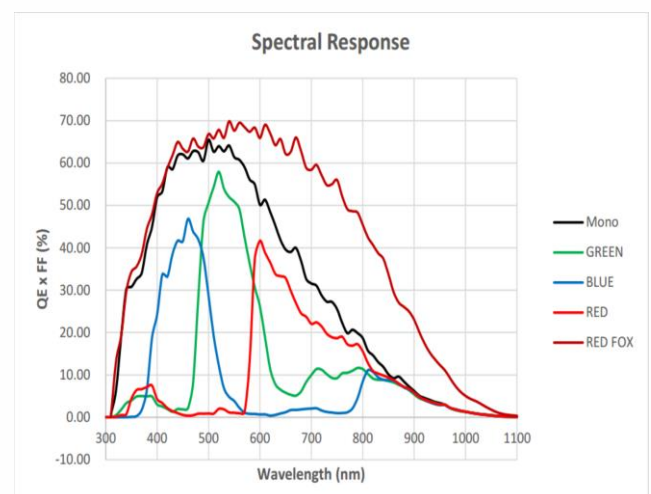

## Specification

Model	MV-CH250-90TM	MV-CH250-90TC
<b>Camera</b>		
Sensor type	CMOS, global shutter	
Sensor model	Gpixel GMAX0505	
Pixel size	2.5 $\mu\text{m}$ $\times$ 2.5 $\mu\text{m}$	
Sensor size	1.1"	
Resolution	5120 $\times$ 5120	
Max. frame rate	41.5 fps @5120 $\times$ 5120	
Dynamic range	63 dB	
SNR	36 dB	
Gain	2.0x to 5.0x	
Exposure time	13 $\mu\text{s}$ to 10 sec	
Exposure mode	Off/Once/Continuous exposure mode	
Mono/color	Mono	Color
Pixel format	Mono 8/10/10p/12/12p	Mono 8/10/12, Bayer BG 8/10/10p/12/12p, YUV422Packed, YUV422_YUYV_Packed, RGB 8, BGR 8
Binning	Supports 1 $\times$ 1, 1 $\times$ 2, 1 $\times$ 4, 2 $\times$ 1, 2 $\times$ 2, 2 $\times$ 4, 4 $\times$ 1, 4 $\times$ 2, 4 $\times$ 4	
Decimation	Supports 1 $\times$ 1, 1 $\times$ 2, 1 $\times$ 4, 2 $\times$ 1, 2 $\times$ 2, 2 $\times$ 4, 4 $\times$ 1, 4 $\times$ 2, 4 $\times$ 4	
Reverse image	Supports horizontal and vertical reverse image output	
<b>Electrical feature</b>		
Data interface	10 Gigabit Ethernet, compatible with Gigabit Ethernet	
Digital I/O	12-pin Hirose connector provides power and I/O, including opto-isolated input $\times$ 1 (Line 0), opto-isolated output $\times$ 1 (Line 1), bi-directional non-isolated I/O $\times$ 1 (Line 2), and RS-232 $\times$ 1	
Power supply	9 VDC to 24 VDC	
Power consumption	Typ. 9.7 W@12 VDC	Typ. 10.0 W@12 VDC
<b>Mechanical</b>		
Lens mount	C-mount, optical back focal length 17.52 mm (0.7") M58-mount, optical back focal length 11.48 mm (0.5")	
Dimension	74 mm $\times$ 74 mm $\times$ 78.8 mm (2.9" $\times$ 2.9" $\times$ 3.1")	
Weight	C-mount camera: approx. 590 g (1.3 lb.) M58-mount camera: approx. 550 g (1.2 lb.)	
Ingress protection	IP40 (under proper lens installation and wiring)	
Temperature	Working temperature: 0 $^{\circ}\text{C}$ to 50 $^{\circ}\text{C}$ (32 $^{\circ}\text{F}$ to 122 $^{\circ}\text{F}$ ) Storage temperature: -30 $^{\circ}\text{C}$ to 70 $^{\circ}\text{C}$ (-22 $^{\circ}\text{F}$ to 158 $^{\circ}\text{F}$ )	
Humidity	20% to 95% RH, non-condensing	
<b>General</b>		
Client software	MVS or third-party software meeting with GigE Vision Protocol	
Operating system	32/64-bit Windows XP/7/10	
Compatibility	GigE Vision V2.0, GenICam	
Certification	CE, FCC, RoHS, KC	

## Dimension

C-mount camera:

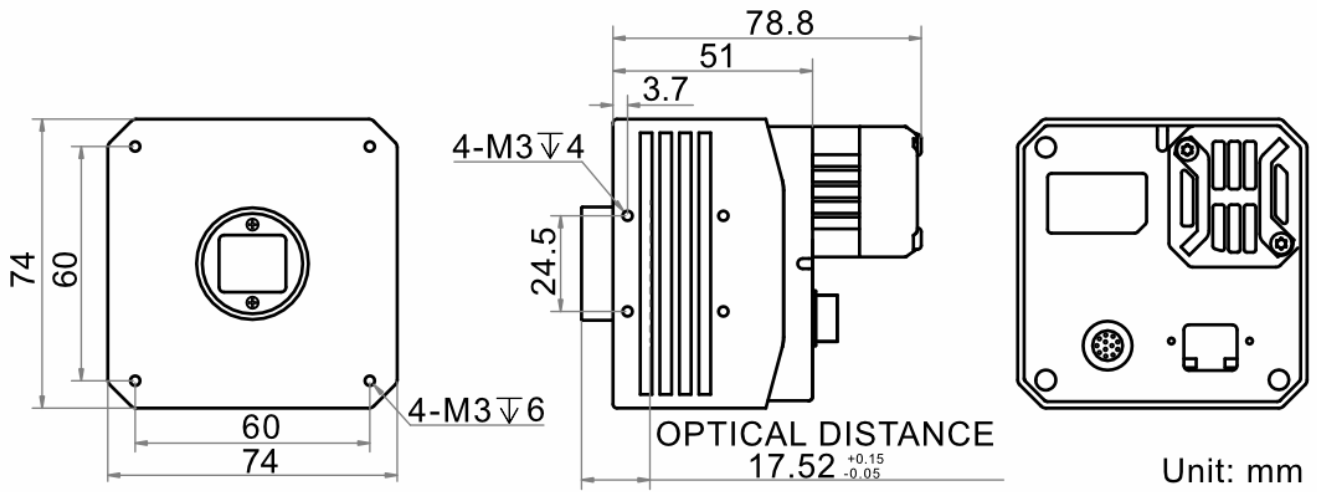

M58-mount camera:

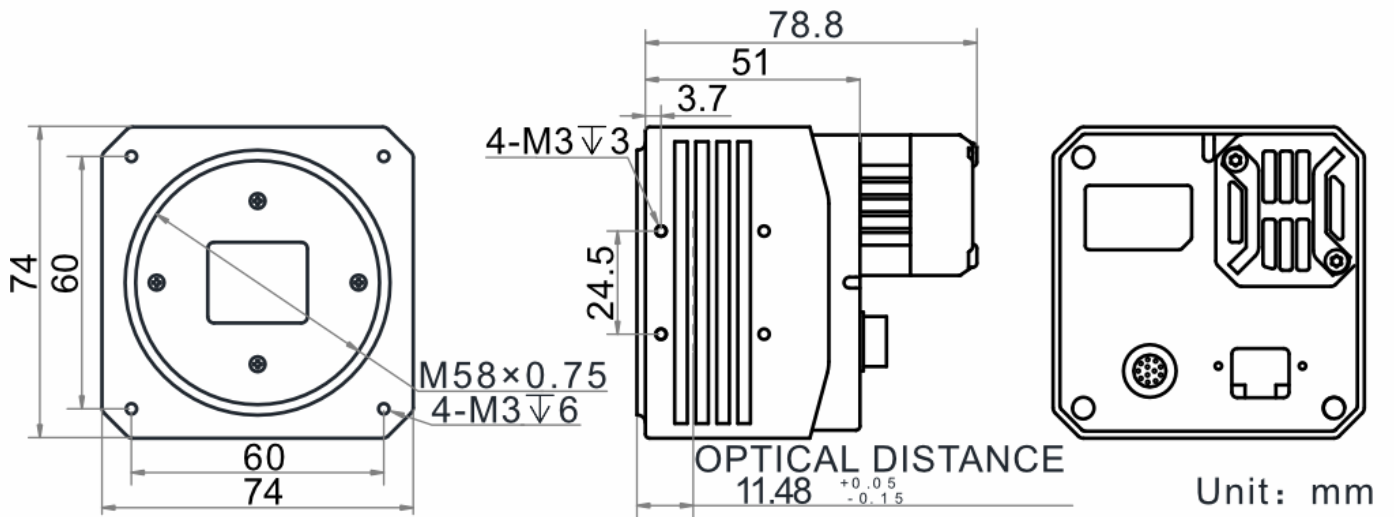

Distribution Partner:



**SCORPION  
VISION**