

MV-CB016-10GM/C

1.6 MP 1/2.9" CMOS GigE Board Level Camera



GEN*i*CAM

GIG*E*
VISION

Introduction

MV-CB016-10GM/C camera adopts Sony® IMX296 sensor to provide high-quality images. It uses GigE interface to transmit images in real time, and its max. frame rate can reach 65.2 fps in full resolution. The camera is small in size, which can meet different spatial requirements.

Key Feature

- Supports auto or manual adjustment of gain, exposure time, white balance, manual adjustment of Gamma correction, LUT, Binning, etc.
- Adopts noise reduction function to provide high-quality images.
- Adopts GigE interface and max. transmission distance of 100 meters without relay.
- Compatible with GigE Vision V2.0 Protocol, GenICam Standard, and third-party software based on the protocol and standard.

Applicable Industry

Electronic semiconductor, factory automation, logistics, bottle detection, medicine packing, etc.

Available Model

- Mono camera with M12-mount: MV-CB016-10GM-S
- Color camera with M12-mount: MV-CB016-10GC-S
- Mono camera with C-mount: MV-CB016-10GM-C
- Color camera with C-mount: MV-CB016-10GC-C

Sensor Quantum Efficiency

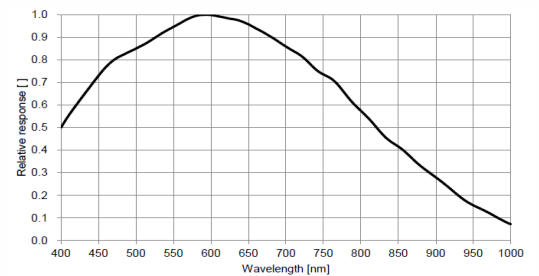

MV-CB016-10GM

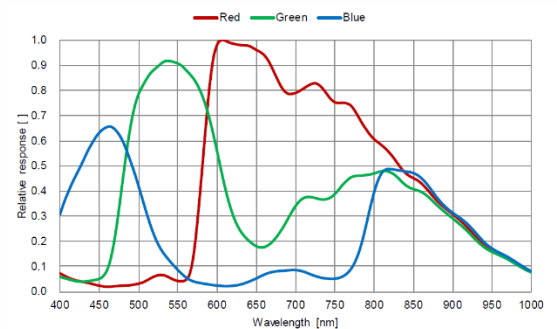

MV-CB016-10GC



Specification

Model	MV-CB016-10GM	MV-CB016-10GC
Camera		
Sensor type	CMOS, global shutter	
Sensor model	Sony® IMX296	
Pixel size	3.45 μm × 3.45 μm	
Sensor size	1/2.9"	
Resolution	1440 × 1080	
Max. frame rate	65.2 fps @1440 × 1080	
Dynamic range	74 dB	
SNR	41 dB	
Gain	0 dB to 24 dB	
Exposure time	UltraShort exposure mode: 1 μs to 14 μs	
	Standard exposure mode: 15 μs to 10 sec	
Exposure mode	Off/Once/Continuous exposure mode	
Mono/color	Mono	Color
Pixel format	Mono 8/10/10p/12/12p	Mono 8/10/12, Bayer RG 8/10/10p/12/12p, YUV422Packed, YUV422_YUYV_Packed, RGB 8, BGR 8
Binning	Supports 1 × 1, 1 × 2, 1 × 4, 2 × 1, 2 × 2, 2 × 4, 4 × 1, 4 × 2, 4 × 4	
Decimation	Supports 1 × 1, 1 × 2, 1 × 4, 2 × 1, 2 × 2, 2 × 4, 4 × 1, 4 × 2, 4 × 4	
Reverse image	Supports horizontal and vertical reverse image output	
Electrical features		
Data interface	Gigabit Ethernet, compatible with Fast Ethernet	
Digital I/O	6-pin connector provides power and I/O, including non-isolated input × 1 (Line 0), non-isolated output × 1 (Line 1), and bi-directional non-isolated I/O × 1 (Line 2).	
Power supply	9 VDC to 24 VDC, supports PoE	
Power consumption	Typ. 2.6 W@12 VDC	Typ. 2.7 W@12 VDC
Mechanical		
Lens mount	C-mount or M12-mount	
Dimension	29 mm × 29 mm × 30.2 mm (1.1" × 1.1" × 1.2")	
Weight	Approx. 45 g (0.1 lb.)	
Temperature	Working temperature: 0 °C to 50 °C (32 °F to 122 °F)	
	Storage temperature: -30 °C to 70 °C (-22 °F to 158 °F)	
Humidity	20% to 80% RH, non-condensing	
General		
Client software	MVS or third-party software meeting with GigE Vision Protocol	
Operating system	32/64-bit Windows XP/7/10, 32/64-bit Linux and 64-bit MacOS	
Compatibility	GigE Vision V2.0, GenICam	
Certification	CE, FCC, RoHS, KC	

Dimension

Camera with C-mount:

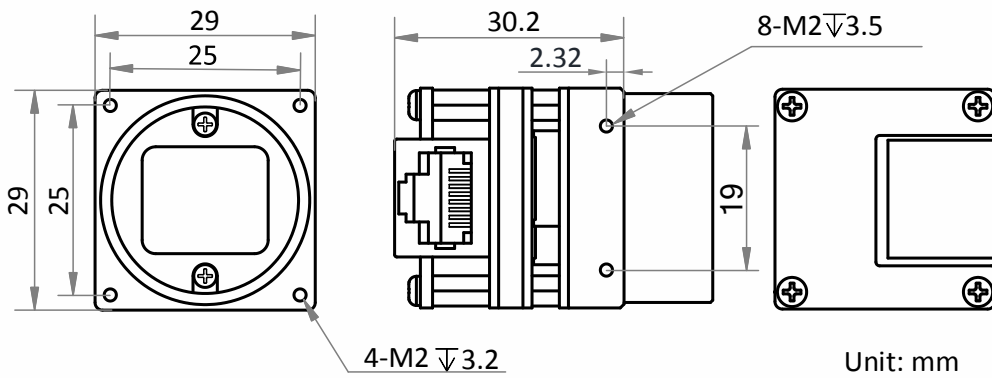

Camera with M12-mount:

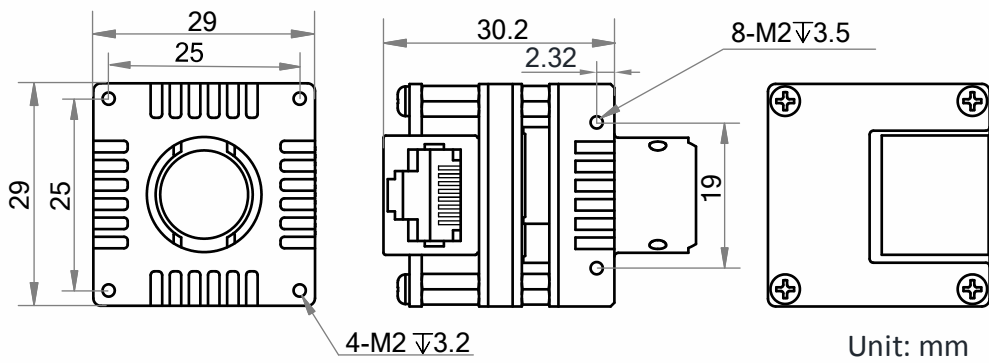

Distribution Partner:



**SCORPION
VISION**