

CyberPower

Installation Manual MBS63AHVHWW

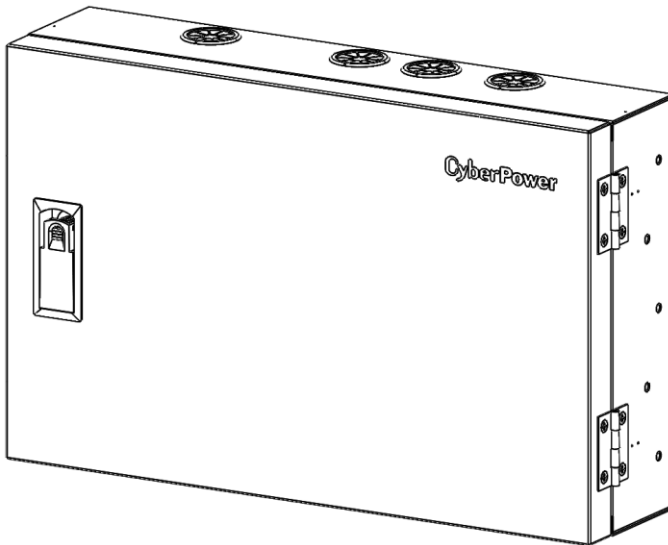

K01-0000767-01

Contents

| | |
|---|----|
| 1. Package Contents | 1 |
| 2. MBS Configuration | 2 |
| 3. MBS Operation Panel Description..... | 3 |
| 4. Cable Gland Replacement Instructions | 4 |
| 5. Two Types of Installation | 5 |
| 5-1. Wall-Mount | 5 |
| 5-2. Rack-Mount..... | 5 |
| 6. Wiring Configuration for Single/Dual Input | 6 |
| 6-1. Power Cables Connect | 7 |
| 6-2. Dry Contact Connection (Option) | 9 |
| 7. Product Specification..... | 11 |
| 8. Contacts | 12 |

1. Package Contents

Table.1: The package should contain the following items:

| NO. | Item | Quantity (PCS) |
|-----|---|----------------|
| 1 | MBS (Maintenance Bypass Switch) Product | 1 |
| 2 | Ear Bracket | 2 |
| 3 | M5*7mm Flat Screw | 10 |
| 4 | Cable Gland | 8 |
| 5 | Installation Manual | 1 |

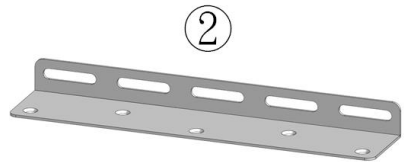
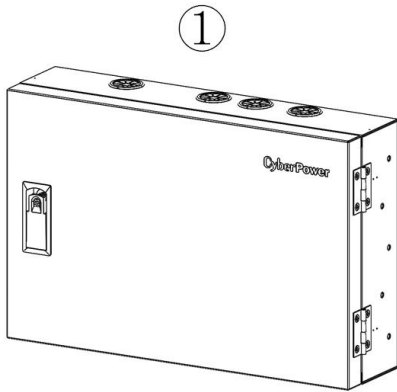

2. MBS Configuration

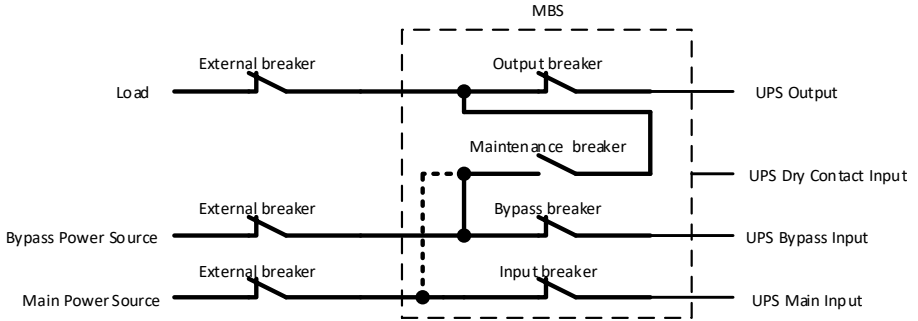

Fig.1: Normal positions for the MBS breakers

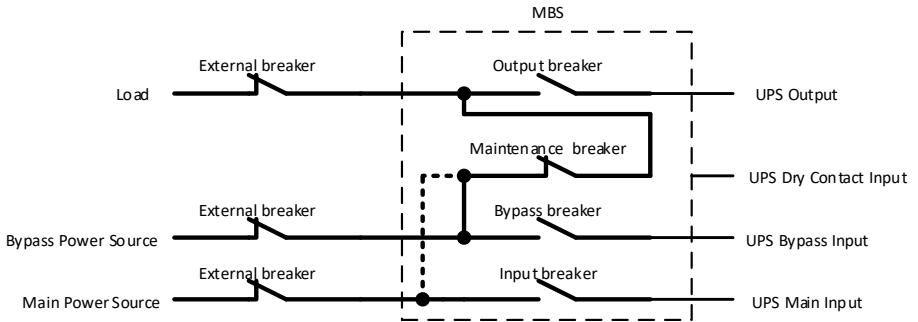

Fig.2: Remove the maintenance cover

Table.2: Breakers specification

| Input Breaker | Bypass Breaker | Maintenance Breaker | Output Breaker | Wire Size |
|---------------|----------------|---------------------|----------------|-----------|
| 400 Vac | 400 Vac | 400 Vac | 400 Vac | 8 AWG |
| 3 Phase | 3 Phase | 3 Phase | 3 Phase | |
| 63 A | 63 A | 63 A | 63 A | |
| 6 kA | 6 kA | 6 kA | 6 kA | |
| 4 Pole | 3 Pole | 3 Pole | 4 Pole | |

3. MBS Operation Panel Description

MBS operation panel description as shown in Fig.3.

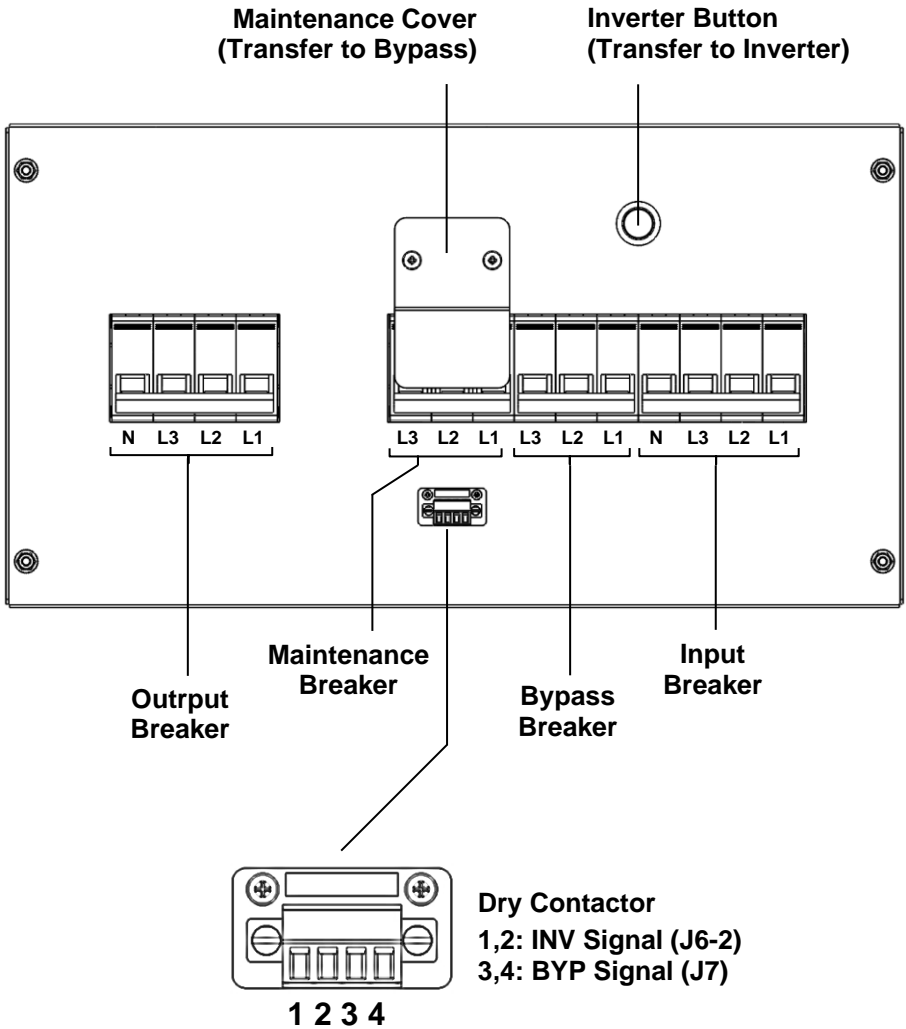

Fig.3: MBS operation panel

4. Cable Gland Replacement Instructions

Please comply with local regulations or user requirements for installation.

Step1. Unscrew and remove the inner panel on the MBS.

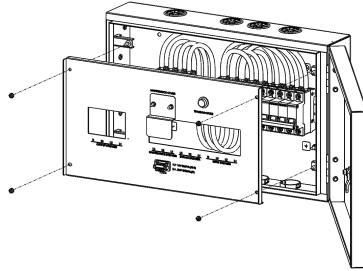

Fig.4: Screw position on the MBS

Step2. Press the clips on both sides and remove the bushing outwards.

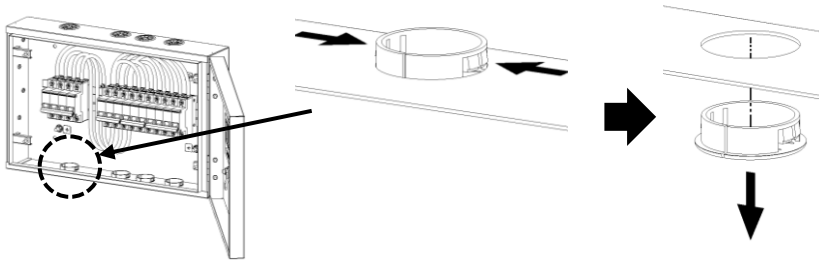

Fig.5: Remove the bushing

Step3. Install the cable gland in the order shown in the figure.

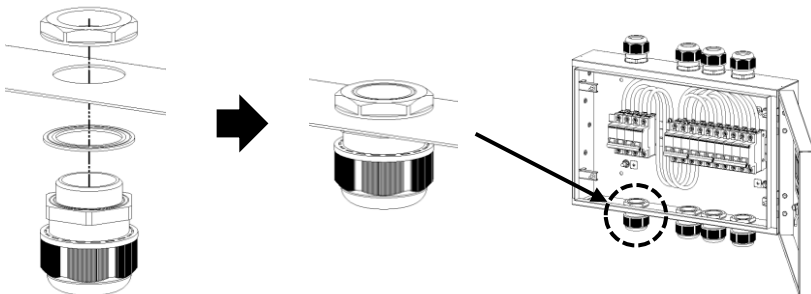

Fig.6: Cable gland installation

5. Two Types of Installation

5-1. Wall-Mount

Step1. Unscrew and remove the inner panel on the MBS.

Step2. Choose a location on the wall and using the recommend screws to install the MBS product.

(Recommend screws: Metric M6 self-tapping screws, 2/8" expansion screws, and wood screws No.12)

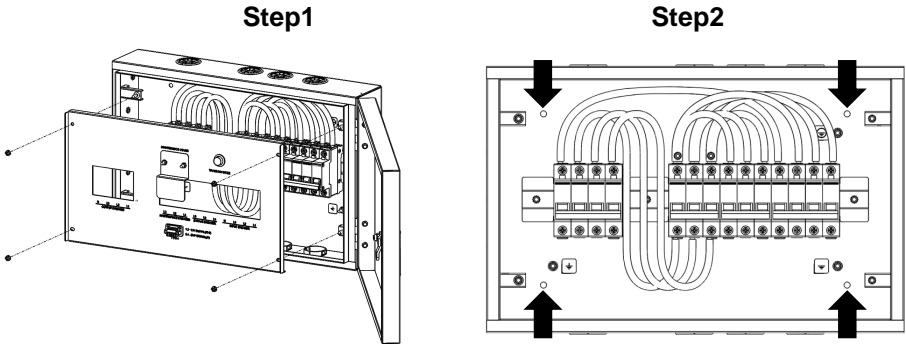

Fig.7: Screws position of the rack-mount

5-2. Rack-Mount

Step1. Installing the mounting ear to the MBS product that using accessory screws (M5*7mm).

Step2. Choose a location on the rack and using the screws and cage nuts to install the MBS product.

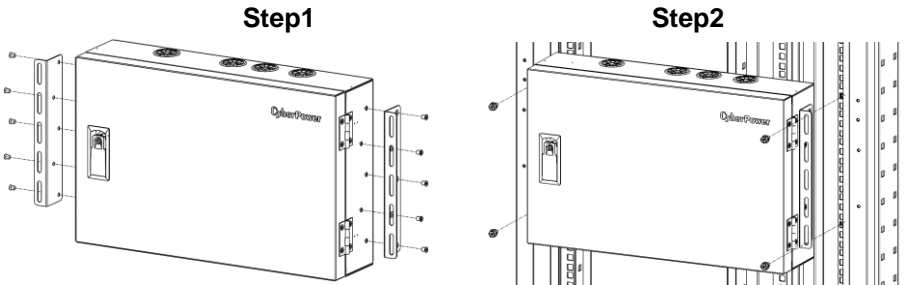

Fig.8: Screws position of the wall-mount

6. Wiring Configuration for Single/Dual Input

Please follow step 1 in Chapter 5-1 to remove the inner panel.
The connection configuration for the single/dual input each shown in Fig.9 and Fig.10:

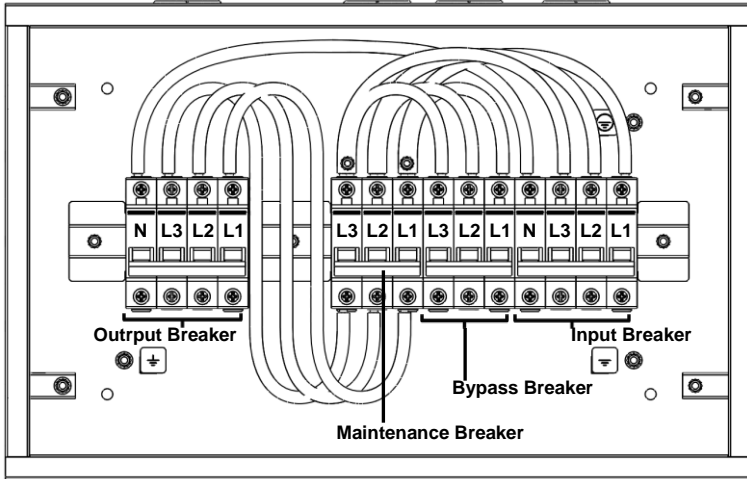

Fig.9: Wiring configuration for the single input

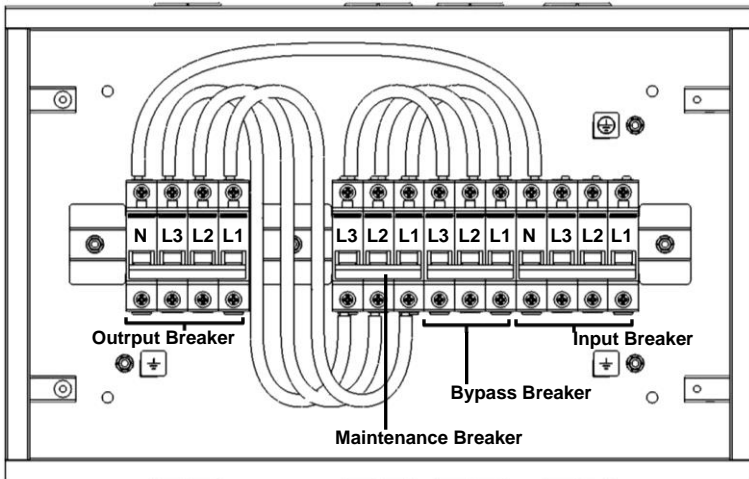

Fig.10: Wiring configuration for the dual input

6-1. Power Cables Connect

Step1. Turn off the external breaker and UPS unit to ensure that the MBS has no power support.

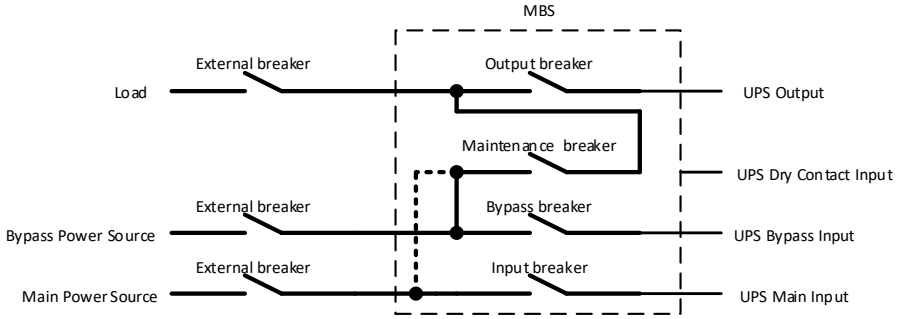

Fig.11: The external breaker location

Step2. Unscrew and remove the inner panel on the MBS.

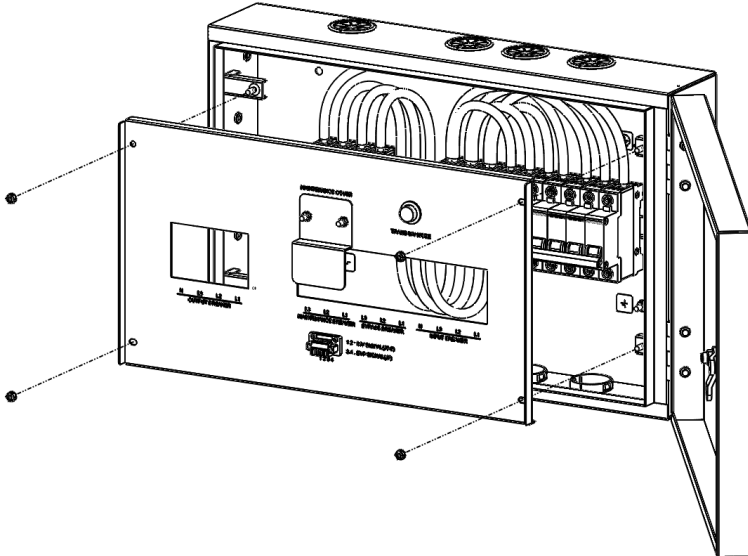

Fig.12: Screws position on the inner panel

Step3. Run the power wire (Cable lugs) through the black bushing, then into the terminal locations of the breaker, and then tighten the screw until snug.

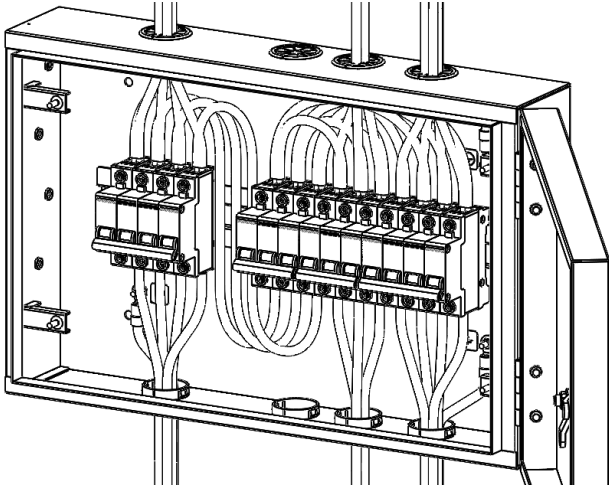

Fig.13: Power wire connection

Step4. Connect ground wire.

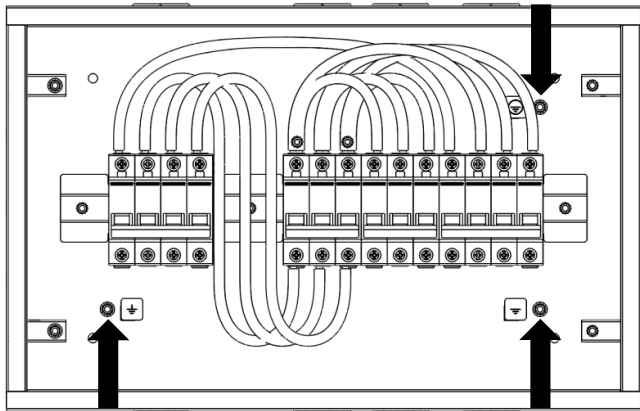

Fig.14: Position of the grounding

6-2. Dry Contact Connection (Option)

Table. 3: Dry contact descriptions

| MBS | UPS | Name | Function |
|------|------|------------|--|
| 1, 2 | J6-2 | INV SIGNAL | Push the button, and then UPS transfers to the Inverter mode. (Push Button, Normally Open) |
| 3, 4 | J7 | BYP SIGNAL | Remove the maintenance cover, and then UPS transfers to the Bypass mode. (Micro Switch, Normally Short) |

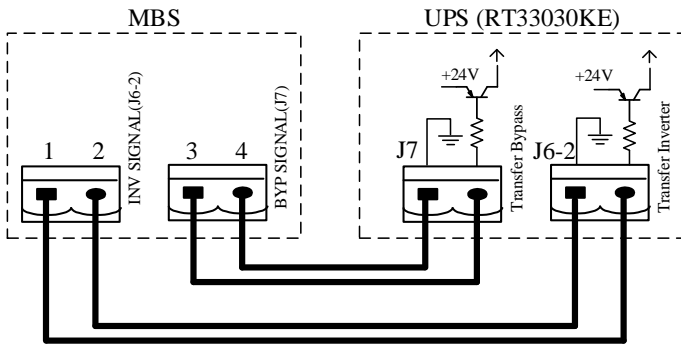

Fig.15: Dry contact connection between the MBS and UPS (RT)

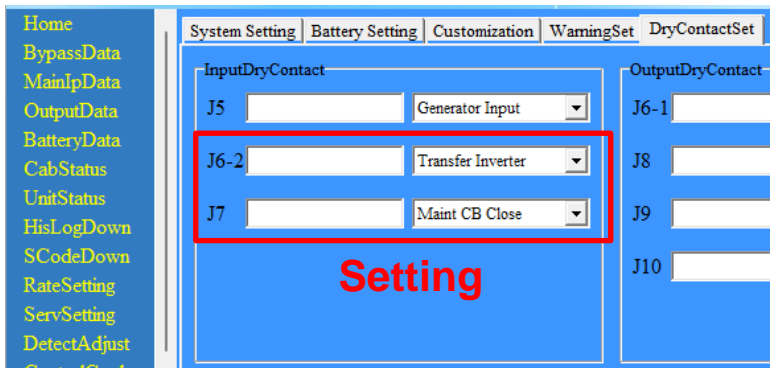

Fig.16: Dry contact setting on the UPS (RT)

Table.4: Dry contact descriptions

| MBS | UPS | Name | Function |
|------|------------|------------|--|
| 1, 2 | J7-2, J7-1 | INV SIGNAL | Push the button, and then UPS transfers to the Inverter mode. (Push Button, Normally Open) |
| 3, 4 | J6-2, J7-1 | BYP SIGNAL | Remove the maintenance cover, and then UPS transfers to the Bypass mode. (Micro Switch, Normally Short) |

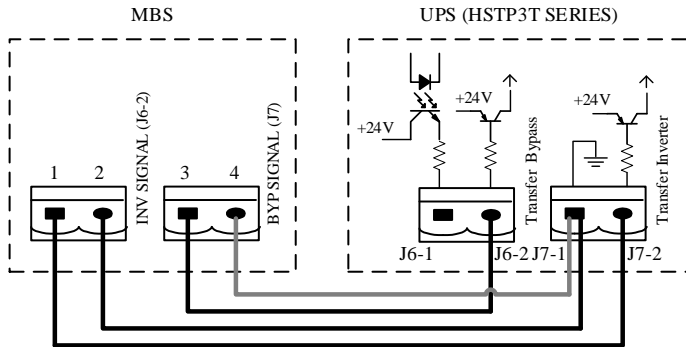

Fig.17: Dry contact connection between the MBS and UPS (HSTP3T)

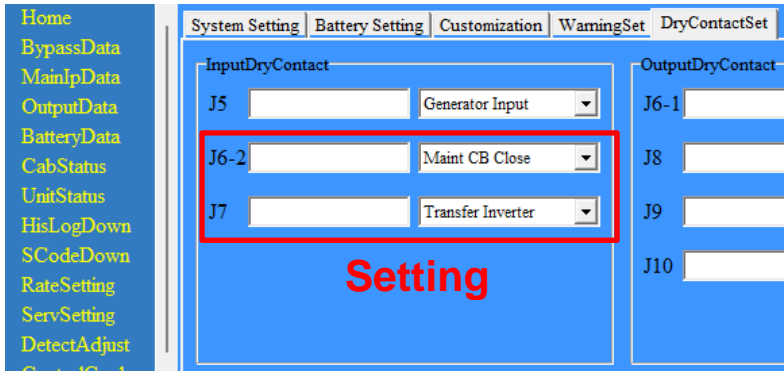

Fig.18: Dry contact setting on the UPS (HSTP3T)

7. Product Specification

Table.5: The MBS product specification

| Environmental Characteristics | | |
|--------------------------------------|-------------|--|
| Items | Unit | Requirements |
| Acoustic noise level at 1 meter | dB | 56.0 |
| Operating Elevation | m | ≤ 1000m Load De-rated 1% per 100m from 1000m and 2000m |
| Operating Relative Humidity | %RH | 0 ~ 95%, non-condensing |
| Operating Temperature | °C | 0 ~ 40 |
| Storage Temperature | °C | 40 ~70 |
| Mechanical Characteristics | | |
| Items | Unit | Parameter |
| Physical | | |
| Dimension, WxDxH | mm | 440 x 280 x 110 |
| Weight | kg | 7.1 |
| Enclosure Construction | N/A | Metal |
| Color | N/A | Black |
| Installation | N/A | Horizontal Rack mount Wall mount |
| Installation Attached to Rack/Tower | N/A | Yes |
| Shipping | | |
| Dimension, WxDxH | mm | 570 x 204 x 360 |
| Weight | kg | 8.7 |
| Electrical Characteristics | | |
| Items | Unit | Parameter |
| Input Voltage Range | Vac | 380 ~ 415 |
| Rated Input Current | A | 63 |

8. Contacts

If there have any technical problems with the product, please contact the installer or CyberPower. During inquiring, please provide the below information:

1. Model Name
2. Serial Number
3. Detailed Issue Description

Taiwan, United Kingdom

Cyber Power Systems, Inc.

11F., No.26, Jinzhuang Rd., Neihu Dist., Taipei City 114, Taiwan

Tel: +886 2 8792 9510

Fax: +886 2 8792 9621

Email: tw.service@cyberpower.com, uk.service@cyberpower.com

Europe, Northern Ireland

Cyber Power Systems B.V.

Flight Forum 3545, 5657DW Eindhoven, The Netherlands

Tel: +31 40 2348170

Fax: +31 40 2340314

Email: eu.service@cyberpower.com

Austria, Germany, Switzerland

Cyber Power Systems GmbH

Edisonstrasse 16, 85716 Unterschleissheim, Germany

Telefon: +49 89 1 222 166 0

Fax: +49 89 1 222 166 29

Email: de.service@cyberpower.com

France

Nitram S.A.

Z.I. Saint-Séverin, 28220 CLOYES, FRANCE

Tél : +33 2 37 98 61 50

Fax: +33 2 37 98 60 04

E-mail: infos@nitram.fr

All Other Regions

Please visit our website for local contact information

CyberPower
www.CyberPower.com

K01-0000767-01